



**Heat Engineering  
Solved Problems  
By  
Dr. P. Raveendiran  
Asst. Professor,  
Mechanical**

## UNIT - 1

### Reciprocating compressor

1.A single stage reciprocating compressor takes  $1\text{m}^3$  of air per minute at 1.013 bar and  $15^\circ\text{C}$  and delivers it at 7 bar. Assuming that the law of compression is  $P_v^{1.35} = \text{constant}$ , and the clearance is negligible, calculate the indicated power?

#### Solution

Volume of air taken in,  $V_1 = 1 \text{ m}^3/\text{min}$

Intake pressure,  $p_1 = 1.013 \text{ bar}$

Initial temperature,  $T_1 = 15 + 273 = 288 \text{ K}$

Delivery pressure,  $P_2 = 7 \text{ bar}$

Law of compression:  $P_v^{1.35} = \text{constant}$

#### Indicated power I.P.:

Mass of air delivered per min.,

$$m = \frac{p_1 v_1}{RT_1} = \frac{1.013 \times 10^5 \times 1}{287 \times 288} = 1.266 \text{ kg / min}$$

$$\begin{aligned} \text{Delivery temperature, } T_2 &= T_1 \left( \frac{p_2}{p_1} \right)^{(n-1/n)} \\ &= 288 \left( \frac{7}{1.013} \right)^{(1.35-1)/1.35} = 475.2 \text{ K} \end{aligned}$$

$$\begin{aligned} \text{Indicated work} &= \frac{n}{n-1} mR(T_2 - T_1) \text{ kJ / min} \\ &= \frac{1.35}{1.35-1} \times 1.226 \times 0.287(475.2 - 288) = 254 \text{ kJ / min} \end{aligned}$$

$$\text{i.e., Indicated power I.P} = \frac{254}{60} = 4.23 \text{ kW. (Ans)}$$

2. An air compressor cylinder has 150mm bore and 150mm stroke and the clearance is 15%. It operates between 1 bar, 27°C and 5 bar. Take polytropic exponent  $n=1.3$  for compression and expansion processes find?

- i. Cylinder volume at the various salient points of in cycle.
- ii. Flow rate in  $m^3/\text{min}$  at 720 rpm and .
- iii. The deal volumetric efficiency.

**Given**

$$\begin{aligned}
 D &= 150 \times 10^{-3} \text{m} & P_2 &= 5 \times 10^5 \text{ N/m}^2 \\
 L &= 150 \times 10^{-3} \text{ m} & T_1 &= 27 + 273 = 300 \text{K} \\
 V_c &= 0.15 V_s & N &= 720 \text{rpm} \\
 P_1 &= 1 \times 10^5 \text{ N/m}^2 & p v^n &= C n = 1.3
 \end{aligned}$$

**Find**

- i.  $V_1, V_2, V_3, V_4$
- ii. FAD ( $V_a$ )
- iii.  $\eta_v$

**Solution**

$$V_1 = V_c + V_s$$

$$V_s = \frac{\pi}{4} D^2 L N = \frac{\pi}{4} (0.15)^2 \times 0.15 \times 720 = 1.9085 m^3 / \text{min}$$

$$V_c = 0.15 V_s$$

$$= 0.15 \times 1.9085$$

$$V_c = 0.2862 m^3 / \text{min}$$

$$V_1 = V_c + V_s$$

$$= 0.2862 + 1.9085$$

$V_1 = 2.1948$	$m^3 / \text{min}$
----------------	--------------------

$$P_1 V_1^n = P_2 V_2^n$$

$$V_2 = V_1 \left( \frac{P_1}{P_2} \right)^{1/n}$$

$$= 2.1948 \left( \frac{1 \times 10^5}{5 \times 10^5} \right)^{1/1.3}$$

$$V_2 = 0.6366 \text{ m}^3/\text{min}$$

$$V_3 = 0.2862 \text{ m}^3/\text{min} = V_c$$

$$V_c = V_3 \quad \therefore$$

$$P_3 V_3^n = P_4 V_4^n$$

$$V_4 = V_3 \left( \frac{P_3}{P_4} \right)^{1/n}$$

### WKT

$$P_2 = P_3$$

$$P_1 = P_4$$

$$\therefore V_4 = V_3 \left( \frac{P_2}{P_1} \right)^{1/n}$$

$$= 0.2862 \left[ \frac{5 \times 10^5}{1 \times 10^5} \right]^{1/1.3}$$

$$V_4 = 0.98674 \text{ m}^3/\text{min}$$

$$\therefore \text{Volumetric efficiency } (\eta_v) = 1 + k - k \left( \frac{P_2}{P_1} \right)^{1/n}$$

$$k = \text{Clearance Ratio} = \frac{V_c}{V_s} = \frac{0.2862}{1.9085}$$

$$K = 0.1499$$

$$\therefore \eta_v = 1 + 0.1499 - 0.1499 \left[ \frac{5}{1} \right]^{1/1.3}$$

$$\eta_v = 0.633 = 63.3\%$$

$$\eta_v = 63.3\%$$

∴ WKT

$$\eta_v = \frac{FAD}{V_s}$$

$$\begin{aligned}\therefore FAD &= \eta_v \times V_s \\ &= 0.633 \times 1.9085\end{aligned}$$

$FAD = 1.2083 \text{ m}^3/\text{min}$
---------------------------------------

**3. Calculate the diameter and stroke for a double acting single stage reciprocating air compressor of 50kW having induction pressure  $100 \text{ kN/m}^2$  and temperature  $150^\circ\text{C}$ . The law of compression is  $PV^{1.2} = C$  and delivery pressure is  $500 \text{ kN/m}^2$ . The revolution/sec = 1.5 and mean piston speed in 150 m/min. Clearance is neglected.**

**Given:**

Double acting single stage

Compressor

$$IP = 50\text{kW}$$

$$P_1 = 100 \times 10^3 \text{ N/m}^2$$

$$T_1 = 15 + 273 = 288\text{K}$$

$$PV^{1.2} = C \quad \therefore n=1.2$$

$$P_2 = 500 \times 10^3 \text{ N/m}^2$$

$$N = 1.5 \text{ rps} = 1.5 \times 60 \text{ rpm}$$

$$2LN = 150\text{m/min (Double acting )}$$

**Find**

- i. D and L

**Solution**

For double acting compressor average piston speed = 2LN

$$\therefore 2LN = 150 \text{ m/min}$$

$$\therefore L = \frac{150}{2 \times 1.5 \times 60} = 0.833\text{m}$$

$L = 0.833 \text{ m}$
-----------------------

### To Find D

$$IP = W \cdot N_w$$

where

$N_w$  = Number of working stroke

For Double acting  $N_w = 2N$

For single acting  $N_w = N$

$$\therefore N_w = 2 \times 1.5 \times 60 = 180 \text{ rpm}$$

$$\begin{aligned} \therefore W.D/\text{cycle} &= \frac{n}{n-1} p_1 V_1 \left[ \left( \frac{p_2}{p_1} \right)^{\frac{n-1}{n}} - 1 \right] \\ &= \frac{1.2}{1.2-1} \times 100 \times 10^3 \left( \frac{\pi}{4} D^2 \times 0.833 \right) \times \left[ \left( \frac{500}{100} \right)^{\frac{0.2}{1.2}} - 1 \right] \end{aligned}$$

$$W = 120764.2 D^2 \quad \text{N-m}$$

$$\therefore IP = \frac{W \cdot N_w}{60}$$

$$50 \times 10^3 = \frac{120764.2 D^2 \times 180}{60}$$

$$D^2 = 0.1380$$

$$D = 0.371 \text{ m}$$

**4.A single acting reciprocating air compressor has cylinder diameter and stroke of 200 mm and 300 mm respectively. The compressor sucks air at 1 bar and 27°C and delivers at 8 bar while running at 100 r.p.m Find: 1. Indicated power of the compressor; 2. Mass of air delivered by the compressor per minute; and 3. temperature of the delivered by the compressor. The compression follows the law  $P_V^{1.25} = C$  Take R as 287 J/kg K.**

**Solution.**

**Given**

$$D = 200 \text{ mm} = 0.2 \text{ m};$$

$$L = 300 \text{ mm} = 0.3 \text{ m};$$

$$p_1 = 1 \text{ bar} = 1 \times 10^5 \text{ N/m}^2;$$

$$T_1 = 27^\circ\text{C} = 27 + 273 = 300\text{K};$$

$$p_2 = 8 \text{ bar};$$

$$N = 100 \text{ r.p.m}$$

$$n=1.25;$$

$$R = 287 \text{ J/kg K}$$

### 1. Indicated power of the compressor

$$V_1 = \frac{\pi}{4} D^2 L = 0.0094 \text{ m}^3$$

We know that workdone by the compressor for polytropic compression of air as

$$\begin{aligned} W &= \frac{n}{n-1} p_1 V_1 \left[ \left( \frac{p_2}{p_1} \right)^{\frac{n-1}{n}} - 1 \right] \\ &= \frac{1.25}{1.25-1} \times 1 \times 10^5 \times 0.0094 \left[ \left( \frac{8}{1} \right)^{\frac{1.25}{1.25-1}} - 1 \right] N - m \\ &= 4700(1.516-1) = 2425 \text{ N-m} \end{aligned}$$

Since the compressor is single acting, therefore number of working strokes per minute,

$$N_w = N = 100$$

∴ Indicated power of the compressor

$$= \frac{W \times N_w}{60} = \frac{2425 \times 100}{60} = \mathbf{4042 \text{ kW}}$$

### 2. Mass of air delivered by the compressor per minute

Let  $m$  = Mass of air delivered by the compressor per stroke.

$$\text{We know that } P_1 V_1 = mRT_1$$

$$\therefore m = \frac{P_1 V_1}{RT_1} = \frac{1 \times 10^5 \times 0.0094}{287 \times 300} = 0.0109 \text{ kg per stroke}$$

$$\text{and mass delivered minute} = m \times N_w = 0.0109 \times 100 = \mathbf{1.09 \text{ kg}}$$

### 3. Temperature of air delivery by the compressor

Let  $T_2$  = Temperature of air delivered by the compressor.

We know that 
$$\frac{T_2}{T_1} = \left(\frac{p_2}{p_1}\right)^{\frac{n-1}{n}} = \left(\frac{8}{1}\right)^{\frac{1.25-1}{1.25}} = 8^{0.2} = 1.516$$

$$T_2 = 1.516 \times T_1 = 1.516 \times 300 = 454.8 \text{ K} = \mathbf{181.8^\circ\text{K}}$$

**5.A single –stage double –acting air compressor is required to deliver 14 m<sup>3</sup> of air per minute measured at 1.013 bar and 15°C. The delivery pressure is 7 bar and the speed 300 r.p.m. Take the clearance volume as 5% of the swept volume with the compression and expansion index of  $\eta = 1.3$  Calculate:**

- i. Swept volume of the cylinder;
- ii. The delivery temperature;
- iii. Indicated power.

#### Solution

Quantity of air to be delivered	=	14 m <sup>3</sup> /min
Intake pressure and temperature	$p_1$	= 1.013 bar,
	$T_1$	= 15 + 273 = 288 K
Delivery pressure	$p_2$	= 7 bar
Compressor speed,		N = 300 r.p.m
Clearance volume,		$V_c = 0.05 V_s$
Compression and expansion index		n=1.3

**Swept volume of the cylinder,  $V_s$ :**

$$\text{Swept volume } V_s = V_1 - V_3 = V_1 - V_c = V_1 - 0.05 V_s$$

$$V_1 - V_4 = \frac{\text{FAD}}{N_w}$$

$$\text{and } V_1 - V_4 = \frac{14}{300 \times 2} = 0.0233 \text{ m}^3$$

$$\text{Now, } V_1 = 1.05 V_s \text{ and } \frac{V_4}{V_3} = \left(\frac{p_2}{p_1}\right)^{\frac{1}{n}} = \left(\frac{7}{1.013}\right)^{\frac{1}{1.3}} = 4.423$$

$$\text{i.e., } V_1 - V_3 = 4.423 V_s = 4.423 \times 0.05 V_s = 0.221 V_s$$

$$\therefore (V_1 - V_4) = 1.05 V_s - 0.221 V_s = 0.829 V_s = 0.0233 \text{ m}^3$$



$$\therefore V_8 \frac{0.0233}{1.05 - 0.221} = 0.0281 \text{ m}^3$$

**i.e Swept volume of the cylinder = 0.0281 m<sup>3</sup> .**

**ii. The delivery temperature, T<sub>2</sub>**

Using the relation 
$$\frac{T_2}{T_1} = \left( \frac{p_2}{p_1} \right)^{\frac{n-1}{n}}$$

$$\therefore T_2 = T_1 \times \left( \frac{p_2}{p_1} \right)^{\frac{n-1}{n}} = 288 \times \left( \frac{7}{1.013} \right)^{\frac{1.3-1}{1.3}} = 450 \text{ K}$$

$$\therefore \text{Delivery temperature} = 450 - 273 = 177^\circ\text{C}$$

**iii Indicated power:**

$$\begin{aligned} \text{Indicated power} &= \frac{n}{n-1} p_1 (V_1 - V_4) \left\{ \left( \frac{p_2}{p_1} \right)^{\frac{n-1}{n}} - 1 \right\} \\ &= \frac{1.3}{1.3-1} \times \frac{1.013 \times 10^5 \times 14}{10^3 \times 6} \left\{ \left( \frac{7}{1.013} \right)^{\frac{1.3-1}{1.3}} - 1 \right\} \\ &= 57.56 \text{ kW} \end{aligned}$$

$$\text{Indicated power} = 57.56 \text{ kW}$$

**6. A single stage single acting air compressor delivers 0.6 kg of air per minute at 6 bar . The temperature and pressure at the end of suction stroke are 30°C and 1 bar. The bore and stroke of the compressor are 100 mm and 150 mm respectively. The clearance is 3% of the swept volume Assuming the index of compression and expansion to be 1.3. find:**

- i. Volumetric efficiency of the compressor
- ii. Power required if the mechanical efficiency is 85%, and
- iii. Speed of the compressor (r.p.m)

**Given**

Mass of air delivered,	m=0.6kg/min
Delivery Pressure,	p <sub>2</sub> =6 bar
Induction Pressure,	p <sub>1</sub> =6 bar

Induction temperature,  $T_1 = 30 + 273 = 303 \text{ K}$   
 Bore,  $D = 100\text{mm} = 0.1\text{m}$   
 Stroke length,  $L = 150\text{mm} = 0.15 \text{ m}$   
 Clearance volume,  $V_c = 0.03 V_s$   
 Mechanical efficiency  $\eta_{\text{mech}} = 85\%$

**i. Volumetric efficiency of the compressor,  $\eta_{\text{vol}}$ :**

$$\eta_{\text{vol}} = 1 + k - k \left( \frac{P_2}{P_1} \right)^{\frac{1}{n}}$$

Where  $k = \frac{V_c}{V_s} = 0.03$

$$\therefore \eta_{\text{vol}} = 1 + 0.03 - 0.03 \left( \frac{6}{1} \right)^{\frac{1}{1.3}} = 0.91096 \text{ or } 91.096\%$$

**ii. Power required if the mechanical efficiency is 85%, and**

$$\text{Indicated power} = \frac{n}{n-1} mRT_1 \left[ \left( \frac{P_2}{P_1} \right)^{\frac{n-1}{n}} - 1 \right]$$

$$\frac{1.3}{1.3-1} \times \frac{0.6}{60} \times 0.287 \times 303 \left[ \left( \frac{6}{1} \right)^{\frac{1.3-1}{1.3}} - 1 \right] = 1.93 \text{ kW}$$

$$\therefore \text{Power required to drive the compressor} = \frac{1.93}{\eta_{\text{mech}}} = \frac{1.93}{0.85} = 2.27 \text{ kW}$$

**iii. Speed of the compressor (r.p.m)**

$$\text{Free air delivery, F.A.D} = \frac{mRT_1}{P_1} \times \frac{0.6 \times 0.287 \times 1000 \times 303}{1 \times 10^5} = 0.5218 \text{ m}^3/\text{min}$$

$$\text{Displacement volume} = \frac{\text{F.A.D}}{\eta_{\text{vol}}} = \frac{0.5218}{0.91096} = 0.5728 \text{ m}^3/\text{min}$$

Also  $0.5728 = \frac{\pi}{4} D^2 L \times N$  (for single – acting compressor)

or  $0.5728 = \frac{\pi}{4} 0.1^2 \times 0.15 \times N$

$$\therefore \text{Speed of compressor } N = \frac{0.5728 \times 4}{\pi \times 0.1^2 \times 0.15} = 486.2 \text{ r.p.m}$$

**7.A single stage , single air compressor running at 1000 r.p.m delivers air at 25 bar . For this purpose the induction and free air conditions can be taken as 1.013 bar and 15°C and the free air delivery as 0.25 m<sup>3</sup>/min. The clearance volume is 3% of the swept volume and the stroke bore ratio is 1:2:1 Take the index of compression and expansion as 1.3. calculate also the indicated power and the isothermal efficiency**

**Given data:-**

With clearance volume

Single stage single acting air compressor

N=1000 rpm

$p_2 = 25 \text{ bar} = 25 \times 10^5 \text{ N/m}^2$

$T_1 = 15^\circ = 273 + 15 = 288\text{K}$

$V_c = 0.03V_s$

$$\frac{V_c}{V_s} = k = 0.03$$

$$\frac{\text{Stroke}(D)}{\text{Bore}(L)} = \frac{1}{2}$$

**L = 2D**

n = 1.3

$PV^n = C$  (polytropic process) To find

i.  $\eta_v$ , D and L

ii. (I.P) and  $\eta_{Iso}$

$$\text{i. } \eta_v = 1 + k - k \left( \frac{P_2}{P_1} \right)^{\frac{1}{n}}$$

$$\eta_v = 1 + 0.03 - 0.03 \left( \frac{25 \times 10^5}{1.013 \times 10^5} \right)^{\frac{1}{1.3}}$$

$$\eta_v = 0.6766$$

$$\text{ii. } IP = \frac{W_{poly} \times N}{60}$$

Inductor power = I.P

$$W_{poly} = \frac{n}{n-1} p(V_1 - V_4) \left[ \left( \frac{P_2}{P_1} \right)^{\frac{n-1}{n}} \right]$$

$$\therefore \eta_v = \frac{FAD/V_a}{V_s}$$

$$V_s = \frac{V_a}{\eta_v} = \frac{0.25}{0.6766}$$

$$V_s = 0.369 \text{ m}^3/\text{min}$$

$$V_s = \frac{\pi}{4} \times D^2 \times L$$

$$0.369 = \frac{\pi}{4} \times D^2 \times 2D = \frac{\pi D^3}{2}$$

$$D = 0.617 \text{ m} = 617 \text{ mm}$$

$$L = 2D = 2 \times 0.617$$

$$L = 1234 \text{ mm}$$

$$V_c = 0.011 \text{ m}^3/\text{min} = V_3$$

$$V_1 = V_c + V_s$$

$$V_1 = 0.011 + 0.369$$

### 3-4 is expansion

$$pv^n = C$$

$$\frac{P_4}{P_3} = \left( \frac{v_3}{v_4} \right)^n$$

$$\frac{v_4}{v_3} = \left( \frac{P_3}{P_4} \right)^{\frac{1}{n}} = \left( \frac{P_2}{P_1} \right)^{\frac{1}{n}}$$

$$V_4 = V_3 \left( \frac{P_2}{P_1} \right)^{\frac{1}{\eta}}$$

$$V_4 = 0.129 \text{ m}^3/\text{min}$$

$$W_{poly} = \left( \frac{n}{n-1} \right) p (V_1 - V_4) \left[ \left( \frac{P_2}{P_1} \right)^{\frac{n-1}{n}} \right]$$

$$= \frac{1.3}{0.3} \times 1.013 \times 10^5 (0.38 - 0.129) \left[ \left( \frac{2.5}{1.013} \right)^{\frac{0.3}{1.3}} - 1 \right]$$

$$W.D_{poly} = 120713.193 \text{ N-min}$$

$$I.P = \frac{W.D_{poly} \times N}{60}$$

$$I.P = \frac{12713 \times 1000}{60}$$

$$\eta_{iso} = \frac{W_{iso}}{W_{poly}}$$

$$W_{iso} = p_1 (V_1 - V_2) \ln \left( \frac{p_2}{p_1} \right)$$

$$\eta_{iso} = \frac{p_1 (V_1 - V_2) \ln \left( \frac{p_2}{p_1} \right)}{\left( \frac{n}{n-1} \right) p_1 (V_1 - V_4) \left( \frac{p_2}{p_1} \right)^{\frac{\eta-1}{\eta}} - 1}$$

$$\eta_{iso} = \frac{1.013 \times 10^5 \times (0.0380 - 0.129) \ln \left( \frac{25}{1.013} \right)}{120713.19}$$

$$\eta_{iso} = 0.675$$

$$\eta_{iso} = 67.5\%$$

**8. A two stage air compressor air from 1 bar and 20°C to 42 bar. If the law of compression is  $p_v^{1.35} = \text{constant}$  and the intercooling is complete to 20°C, find per kg of air: 1. The work done is compressing; and 2. The mass of water necessary for abstracting the heat in the intercooler, if the temperature rise of the cooling water is 25°C**

$$p_1 = 1 \text{ bar} = 1 \times 10^5 \text{ N/m}^2$$

$$T_1 = 20^\circ \text{C} = 20 + 273 = 293 \text{K}$$

$$p_3 = 42 \text{ bar} = 42 \times 10^5 \text{ N/m}^2$$

$$n = 1.35$$

$$T_3 = 20^\circ \text{C} = 20 + 273 = 293 \text{K}; m = 1 \text{ kg};$$

$$\text{Rise in temperature of cooling water} = 25^\circ \text{C};$$

$$R = 287 \text{ J/kg K } c_p = 1 \text{ kJ /kg K}$$

we know that for complete intercooling. the intercooler pressure

$$p_2 = \sqrt{p_1 p_3} = \sqrt{1 \times 42} = 6.48 \text{ bar}$$

and volume of air admitted for compression

$$V_1 \frac{mRT_1}{p_1} = \frac{1 \times 287 \times 293}{1 \times 10^5} = 0.84 \text{ m}^3 / \text{kg of air}$$

**1. Work done compressing the air**

$$\begin{aligned} W &= \left( \frac{n}{n-1} \right) \times p_1 v_1 \left[ \left( \frac{P_2}{p_1} \right)^{\frac{n-1}{n}} + \left( \frac{P_2}{p_1} \right)^{\frac{n-1}{n}} - 2 \right] \\ &= \frac{1.35}{1.35-1} \times 1 \times 10^5 \times 0.84 \left[ \left( \frac{6.48}{1} \right)^{\frac{1.35-1}{1.35}} + \left( \frac{42}{6.48} \right)^{\frac{1.35-1}{1.35}} - 2 \right] N - m \\ &= 3.24 \times 10^5 (1.62 + 1.62 - 2) = \mathbf{4.017 \times 10^5 \text{ N-m}} \end{aligned}$$

**2. Mass of water necessary for abstracting the heat in the intercooler.**

Let  $m_w =$  Mass of water necessary /kg of air ,and

$T_2 =$  Temperature of the air entering the intercooler.

$$\frac{T_2}{T_1} = \left( \frac{P_2}{P_1} \right)^{\frac{n-1}{n}} = \left( \frac{6.48}{1} \right)^{\frac{1.35-1}{1.35}} = 1.622$$

$$T_2 = T_1 \times 1.622 = 293 \times 1.622 = 475.6 \text{ K}$$

We know that heat gained by water

$$= \text{Heat lost by air}$$

$\therefore m_w \times c_w \times \text{Rise in temperature}$

$$= m c_p (T_2 - T_3)$$

$$m_w \times 4.2 \times 25 = 1 \times 1 (475.6 - 293) = 182.6$$

$$m_w = 1.74 \text{ kg}$$

**9.A two- stage acting reciprocating compressor takes in air at the rate of 0.2 m<sup>3</sup>/s. The intake pressure and temperature of air 0.1MP<sub>a</sub> and 16°C. The air is compressed to a final pressure of .7MP<sub>a</sub>. The intermediate pressure is ideal and intercooling is perfect. The compression index in both the stages is 1.25 and the compressor runs at 600 r.p.m.**

**Neglecting clearance determine:**

- i. The intermediate pressure
- ii. The total volume of each cylinder,
- iii. The power required to drive the compressor and
- iv. The rate of heat rejection in the intercooler.

Take  $c_p = 1.005 \text{ kJ/kg K}$  and  $R = 0.287 \text{ kJ/kg K}$

**Solution .**

Intake volume  $V_1 = 0.2 \text{ m}^3/\text{s}$

Intake pressure  $p_1 = 0.1 \text{ MP}_a,$

Intake temperature  $T_1 = 16 + 273 = 289 \text{ K}$

Final pressure  $p_3 = 0.7 \text{ MP}_a$

Compression index in both stages,  $n_1 = n_2 = n = 1.25$

Speed of the compressor  $N = 600 \text{ r.p.m}$

$$c_p = 1.005 \text{ kJ/kg K}; R = 0.287 \text{ kJ/kg K}$$

**i. The power required to drive the compressor, P<sub>2</sub>:**

$$p_2 = \sqrt{p_1 p_3} = \sqrt{0.1 \times 0.7} = 0.2646 \text{ MP}_a$$

**ii. The total volume of each cylinder ,V<sub>s1</sub>,V<sub>s2</sub>:**

$$\text{We know that } V_{s1} \times \frac{N}{60} = V_1 \text{ or } V_{s1} \times \frac{600}{60} = 0.2$$

$$\therefore V_{s1} \text{ (Volume of L.P cylinder)} = \frac{600 \times 0.2}{60} = 0.02 m^3 \text{ (Ans).}$$

$$\text{Also } p_1 V_{s1} = p_1 V_{s2} \text{ or } V_{s2} = \frac{p_1 V_{s1}}{p_2}$$

$$V_{s2} \text{ (Volume of H.P. Cylinder)} = \frac{0.1 \times 0.02}{0.2646} = 0.00756 m^3 \text{ (Ans)}$$

**iii. The rate of heat rejection in the intercooler:**

$$\text{Mass of air handled, } m = \frac{p_1 V_1}{RT_1} = \frac{(0.1 \times 10^3) \times 0.2}{0.287 \times 289} = 0.241 \text{ kg/s}$$

$$\text{Also, } \frac{T_2}{T_1} = \left( \frac{p_2}{p_1} \right)^{\frac{n-1}{n}} \text{ or } \frac{T_2}{289} = \left( \frac{0.2646}{0.1} \right)^{\frac{1.25-1}{1.25}} \text{ or } T_2 = 351.1 \text{ K}$$

$$\begin{aligned} \therefore \text{Heat rejected in the intercooler} &= m \times c_p \times (T_2 - T_1) \\ &= 0.241 \times 1.005 \times (351.1 - 289) = \mathbf{15.04 \text{ kJ/s or } 15.04 \text{ kW. (Ans)} \end{aligned}$$

**10. A single acting reciprocating air compressor has a swept volume of 2000 cm<sup>3</sup> and runs at 800 rpm. It operates with pressure ratio of 8 and clearance of 5% of the swept volume. Inlet pressure and temperature are 1.013 bar, and 15°C respectively. Assume n=1.25 for both compression and expansion. Find**

- i. Indicated power**
- ii. Volumetric efficiency**
- iii. Mass flow rate**
- iv. FAD**
- v. Isothermal efficiency**
- vi. Actual Power required to drive the compressor if  $\eta_{\text{mech}}=85\%$**

**Given**

Single acting reciprocating compressor

$$V_s = 2000 \text{ cm}^3 = 0.002 \text{ m}^3$$

$$N = 800 \text{ rpm}$$

$$\frac{P_2}{P_1} = \frac{P_3}{P_4} = 8$$



$$\begin{aligned}
V_c &= 5\% V_s \\
&= 0.05 \times 0.002 \\
V_c &= 0.0001 \text{ m}^3 \\
p_1 &= 1.013 \times 10^5 \text{ N/m}^2 \\
T_1 &= 15 + 273 = 288 \text{ K} \\
P_V^n &= C \quad n = 1.25
\end{aligned}$$

**Find: i) IP ii)  $\eta_v$  iii) m iv) FAD( $V_a$ ) v)  $\eta_{iso}$  vi)  $P_{act}$  if  $\eta_m = 85\%$**

**Solution**

WKT

$$\text{Clearance ratio (k)} = \frac{V_c}{V_s} = \frac{0.0001}{0.002}$$

k	=	0.05
---	---	------

$$\begin{aligned}
\therefore \text{Volumetric efficiency } (\eta_v) &= 1 + k - k \left( \frac{P_2}{P_1} \right)^{\frac{1}{n}} \\
&= 1 + 0.05 - 0.05 (8)^{1/1.25} \\
\eta_v &= 78.61\%
\end{aligned}$$

WKT

$$\begin{aligned}
\eta_v &= \frac{FAD}{V_s} \\
FAD &= \eta_v \times V_s \\
&= 0.7861 \times 0.002 \\
&= 1.5722 \times 10^{-3} \text{ m}^3
\end{aligned}$$

$$\begin{aligned}
\frac{FAD}{\text{min}} &= \frac{FAD}{\text{Stroke}} \times \text{Speed} \\
&= 1.5722 \times 10^{-3} \times 800
\end{aligned}$$

$$\therefore FAD = 1.2578 \text{ m}^3/\text{min}$$

To find mass flow rate

$$Pv = mRT$$

$$m = \frac{pV}{RT} = \frac{1.013 \times 10^5 \times 1.2578}{287 \times 288}$$

$$m = 1.542 \text{ kg/min}$$

To find – Indicated power

$$\text{IP} = \frac{W.D \times N_{\omega}}{\text{sec}}$$

$$N_w = N \text{ (single acting)} = 800 \text{ rpm.}$$

$$\text{W.D} = \frac{n}{n-1} mR(T_2 - T_1) \text{ kJ/min.}$$

$$T_2 = T_1 \left( \frac{P_2}{P_1} \right)^{\frac{n-1}{n}}$$

$$= 288(8)^{\frac{1.25-1}{1.25}}$$

$$T_2 = 436.53 \text{ K}$$

$$\therefore \text{W.D} = \frac{1.25}{0.25} \times 1.542 \times 0.287(436.53 - 288)$$

$$\text{W.D} = 328.66 \text{ kJ/min}$$

$$\therefore \text{IP} = \frac{W.D}{s} = \frac{328.66}{60}$$

$$\text{IP} = 5.48 \text{ kW}$$

**To find isothermal efficiency**

$$W_{iso} = P_1 V_1 \ln \left( \frac{P_2}{P_1} \right)$$

$$= mRT_1 \ln \left( \frac{P_2}{P_1} \right)$$

$$= 1.542 \times 0.287 \times 288 \times \ln(8)$$

$$(\text{W.D})_{iso} = 265.04 \text{ kJ/min}$$

$$\eta_{iso} = \frac{(W.D)_{iso}}{(W.D)_{act}}$$

$$\therefore \text{Actual work} = \eta_{mech} \times (\text{W.D})_{theoretical}$$

$$= 0.85 \times 328.66$$

$$(W.D)_{act} = 279.361 \text{ kJ/min}$$

$$\therefore \eta_{iso} = \frac{265.04}{279.361} \times 100$$

$\eta_{iso} = 94.87\%$
------------------------

**11. An air compressor takes in air at 1 bar and 20°C and compresses it according to law  $pv^{1.2}=\text{constant}$ . It is then delivered to a receiver at a constant pressure of 10 bar.  $R=0.287 \text{ kJ/kg K}$ . Determine**

- (i) Temperature at the end of compression
- (ii) Workdone and heat transferred during compression per kg of air.

**Solution**

$$T_1=20+273=293 \text{ K}; P_1=1 \text{ bar}; P_2=10 \text{ bar}$$

Law of compression :  $pv^{1.2}=C$ ;  $R=287 \text{ J/kgK}$

- (i) Temperature at the end of compression  $T_2$

For compression process 1-2, we have

$$\frac{T_2}{T_1} = \left(\frac{P_2}{P_1}\right)^{\frac{n-1}{n}} = \left(\frac{10}{1}\right)^{\frac{1.2-1}{1.2}} = 1.468$$

$$T_2=T_1 \times 1.468 = 293 \times 1.468 = 430 \text{ K or } 157^\circ\text{C}$$

- (ii) Workdone and heat transferred during compression per kg of air:

$$\begin{aligned} \text{Workdone, } W &= mRT_1 \frac{n}{n-1} \left[ \left(\frac{P_2}{P_1}\right)^{\frac{n-1}{n}} - 1 \right] \\ &= 1 \times 0.287 \times 293 \times \left(\frac{1.2}{1.2-1}\right) \left(\frac{10}{1}\right)^{\frac{1.2-1}{1.2}} - 1 = 236.13 \text{ kJ / kg of air} \end{aligned}$$

Heat transferred during compression,

$$\begin{aligned} Q &= W + \Delta U \\ &= \frac{P_1V_1 - P_2V_2}{n-1} + c_v(T_2 - T_1) = (T_2 - T_1) \left[ c_v - \frac{R}{n-1} \right] \\ &= (430-293) \left[ 0.718 - \frac{0.287}{1.2-1} \right] = -98.23 \text{ kJ/kg} \end{aligned}$$

Negative sign indicates heat rejection.

## UNIT – II

1. The cylinder of a non-condensing steam engine is supplied with steam at a pressure of 12 bar. The clearance volume is 1/10 of the stroke volume and the cut-off takes place at 0.25 of the stroke. The back pressure is 1.1 bar. Find the mean effective pressure of the steam on the piston. Assume hyperbolic expansion.

### Solution

$$\text{Given: } p_1=12 \text{ bar; } k=v_c/v_s=1/10=0.1; \quad M=(v_2-v_c)/v_s=0.25; \quad P_b=1.1 \text{ bar}$$

We know that mean effective pressure,

$$\begin{aligned} p_1 M + p_1 (K + M) \ln \left[ \frac{k + 1}{k + M} \right] - P_b \\ = 12 \times 0.25 + 12(0.1 + 0.25) \ln \left( \frac{0.1 + 1}{0.1 + 0.25} \right) - 1.1 \\ = 6.7 \text{ bar Ans.} \end{aligned}$$

2. Estimate the brake power of simple steam engine having 250 mm piston diameter and 40mm piston rod diameter with 250mm stroke length operating at 300 rpm. The initial and back pressure of steam is 8.5 bar and 1.2 bar. Assume 90% mechanical efficiency. Cut-off at 25% of forward stroke neglect clearance.

### Given

D	=	$250 \times 10^{-3} \text{ m}$	$p_1$	=	8.5 bar
L	=	$250 \times 10^{-3} \text{ m}$	$p_b$	=	1.2 bar
d	=	$40 \times 10^{-3} \text{ m}$	$\eta_m$	=	90%
N	=	300 rpm	$V_2$	=	0.25 $V_s$

### Find

B.P

### Solution

$$\eta_m = \frac{BP}{IP}$$

$$\therefore BP = \eta_m \times IP$$

$$\therefore IP = \frac{100 p_{m1} L A_1 N_w}{60} + \frac{100 p_{m2} L A_2 N_w}{60}$$

$$\therefore N_w = N \text{ (assume single acting)}$$

$$\therefore p_{m1} = p_{m2}$$

$$\therefore = \frac{p_l}{r} [I + I_n(r)] - p_b$$

$$r = \text{expansion ratio} = \frac{V_3}{V_2}$$

### WKT

$$\frac{V_2}{V_3} = 0.25$$

$$\therefore \frac{V_3}{V_2} = \frac{1}{0.25} = 4$$

$$\therefore r = 4$$

$$p_m = p_m \frac{8.5}{4} [I + \ln(4)] - 1.2$$

$$p_m = 3.871 \text{ bar}$$

$$\therefore A_1 = \frac{\pi}{4} D^2 = \frac{\pi}{4} \times 0.25$$

$$A_1 = 0.196 \text{ m}^2$$

$$A_2 = \text{Area of Piston rod}$$

$$= A_1 - \frac{\pi}{4} d^2$$

$$= 0.196 - \frac{\pi}{4} (0.04)^2$$

$$A_2 = 0.195 \text{ m}^2$$

$$IP = \frac{100 p_m L N [A_1 + A_2]}{60}$$

$$= \frac{100 \times 3.87 \times 0.25 \times 300 [0.196 + 0.195]}{60}$$

$$IP = 189.195 \text{ KW}$$

$$\therefore Bp = \eta_m \times IP$$

$$= 0.9 \times 189.195$$

$$BP = 170.28 \text{ KW}$$

**3 A compound engine is to develop 90 kW at 100 r.p.m. Steam is supplied at 7.5 bar and the condenser pressure is 0.21 bar. Assuming hyperbolic expansion and expansion ratio of 15, a diagram factor of 0.72 neglecting clearance and losses determine the diameters of the cylinder so that they may develop equal powers. Stroke of each Stroke of each piston = LP cylinder diameter.**

**Solution.**

$$\text{Power to be developed, I.P} = 90 \text{ kW}$$

$$\text{Engine speed, } N = 100 \text{ r.p.m}$$

$$\text{Admission steam pressure, } p_1 = 7.5 \text{ bar}$$

$$\text{Condenser pressure } p_b = 0.21 \text{ bar}$$

$$\text{Expansion ratio, } r = 15$$

$$\text{Diagram factor } D.F. = 0.72$$

**Cylinder diameters,  $D_{L,p}$   $D_{H,p}$ :**

$$\text{Stroke of each piston} = \text{L.P cylinder diameter}$$

$P_{m(\text{actual})}$  referred to L.P. cylinder

$$= D.F \left[ \frac{p_1}{r} (1 + \ln(r)) \right] - p_b$$

$$= 0.72 \left[ \frac{7.5}{15} (1 + \ln 15) - 0.21 \right] = 1.18 \text{ bar}$$

**Indicated power,**

$$IP = \frac{10 p_m (\text{actual}) LAN}{3} = \frac{100 \times 1.18 \times D_{L,p} \times \frac{\pi}{4} D_{L,p}^2 \times 100}{60}$$

$$90 = 308.92 D_{L,p}^3$$

$$D_{L.P} = \left( \frac{90}{308.92} \right)^{1/3} = 0.6629m = 663mm$$

i.e Diameter of low pressure cylinder = 663 mm

**Work done in H.P. cylinder**

$$= p_1 V_1 + p_1 V_1 \ln \frac{V_2}{V_1} - p_2 V_2$$

**But**  $p_1 V_1 = p_2 V_2$

$$\therefore \text{Work done in H.P. cylinder} = p_1 V_1 \ln(r) \text{ H.P} \quad \therefore LP = \frac{V_2}{V_1}$$

$$\text{Work done in L.P cylinder} = p_2 V_2 + p_2 V_2 \ln \frac{V_3}{V_2} - p_b V_3$$

$$= p_2 V_2 + p_2 V_2 \ln(r) \text{ L.P} - p_b V_3 \quad \therefore LP = \frac{V_3}{V_2}$$

Equating work done in H.P. cylinder to that done in L.P cylinder

$$p_1 V_1 \ln(r) \text{ H.P} = p_2 V_2 \ln(r) \text{ L.P} - p_b V_3$$

$$\ln \left( \frac{r_{LP}}{r_{HP}} \right) = \frac{p_b V_3}{p_1 V_1} - 1$$

But  $\frac{V_3}{V_2} = r = 5$

$$\therefore \log_e \left( \frac{r_{LP}}{r_{HP}} \right) = \frac{0.21}{7.5} \times 15 - 1$$

Also  $r_{LP} = \frac{V_3}{V_2}$  and  $r_{HP} = \frac{V_2}{V_1}$   $r_{LP} = \frac{V_3}{V_2}$  and  $r_{HP} = \frac{V_2}{V_1}$  and

$$\ln \left( \frac{r_{LP}}{r_{HP}} \right) = \ln \left( \frac{V_3}{V_2} \right) \times \left( \frac{V_1}{V_2} \right) = \ln \frac{15V_1 2}{V_2^2}$$

$$\ln \left( \frac{15V_1 2}{V_2^2} \right) = \frac{0.21}{7.5} \times 15 - 1$$

$$\ln \frac{V_2^2}{15V_1^2} = 1 \frac{0.21}{7.5} \times 15 = 0.58$$

$$\frac{V_2^2}{15V_1^2} = 1.786, \quad \therefore \frac{V_2^2}{V_1^2} = 26.79$$

$$\therefore \text{Ratio of expansion for H.P cylinder, } r_{H.p} = \frac{V_2}{V_1} = (26.79)^{\frac{1}{2}} = 5.176$$

$$\text{Also } \frac{V_3}{V_2} = \frac{V_3}{V_1} \times \frac{V_1}{V_2} = \frac{15}{v_2/v_1} = \frac{15}{5.176} = 2.9$$

$$\text{Volume of H.P cylinder} = \frac{\pi}{4} \times \frac{0.663}{\sqrt{2.9}} \times 0.663 = \frac{\pi}{4} D_{H.P}^2 \times 0.663$$

$$\therefore \text{Diameter of H.P cylinder} = \mathbf{389 \text{ mm.}}$$

**4. A single cylinder double acting steam engine has piston diameter 250mm stroke 400 mm and diameter of piston rod 50mm. The mean effective pressure on both side of the piston is 2.5 bar determine the Indicated power when the engine runs at 200 r.p.m .**

Single cylinder double acting steam engine

$$D = 250 \times 10^{-3} \text{ m}$$

$$L = 400 \times 10^{-3} \text{ m}$$

$$d = 50 \times 10^{-3} \text{ m}$$

$$p_{m1} = p_{m2} = 2.5 \text{ bar}$$

$$N = 200 \text{ rpm}$$

**Find**

$$\text{i) IP}$$

**Solution**

$$\text{IP} = \frac{100 p_{m1} L A_1 N}{60} + \frac{100 p_{m2} L A_2 N}{60}$$

$$p_{m1} = p_{m2}$$

$$\text{IP} = \frac{100 p_m L N [A_1 + A_2]}{60}$$

$$A_1 = \frac{\pi}{4} D^2 = \frac{\pi}{4} (0.25)^2$$

$$A_1 = 0.049 \text{ m}^2$$



$$A_1 = \frac{\pi}{4} d^2 = 0.049 - \frac{\pi}{4} (0.05)^2$$

$$A_2 = 0.047 \text{ m}^2$$

$$IP = \frac{100 \times 2.5 \times 0.4 \times 200 [0.049 + 0.014]}{60}$$

$$IP = 32 \text{ kW}$$

**5. A single cylinder, double acting non- condensing steam engine 200 mm in diameter and 400 mm in stroke develops 30 kW at 100 r.p.m. The clearance is 10% and cut-off is 40% of stroke. The pressure at the point of cut-off is 5 bar. The compression starts at 80% of the stroke during return stroke. The pressure of the steam on compression curve at 90% of the return stroke is 1.5 bar steam is dry saturated.**

Calculate the actual and minimum theoretical possible specific steam consumption on I.P basis. Take the missing quantity of cut-off as 0.0072 kg/stroke.

**Solution.**

Diameter of engine cylinder,  $D = 200 \text{ mm} = 0.2 \text{ m}$

Length of stroke,  $L = 400 \text{ mm} = 0.4 \text{ m}$

Indicated power developed,  $IP = 30 \text{ kW}$

Engine speed,  $N = 100 \text{ r.p.m}$

Clearance volume  $V_c = 0.14 V_s$

Cut off  $= 0.4 V_s$

Pressure at the point of cut –off,  $P_1 = 5 \text{ bar}$

Steam pressure on compression curve at 90% of the return stroke,

$$P_1 = 1.5 \text{ bar}$$

Missing quantity at cut-off  $= 0.0072 \text{ kg/stroke}$

$$\text{Stroke volume } V_s = \frac{\pi}{4} D^2 \times L = \frac{\pi}{4} \times 0.2^2 \times 0.4 = 0.01256 \text{ m}^3$$

$$V_s - V_c + (1-0.9) V_s = 0.1 V_s + 0.1 V_s = 0.2 V_s$$

$$= 0.2 \times 0.01256 = 0.002512 \text{ m}^3$$

Mass of cushion steam/stroke

$$\begin{aligned}m_c &= \frac{V_5}{V_5} = \frac{V_6}{V_{g5}} \\ &= \frac{0.002512}{1.159} = 0.002167 \text{ kg/stroke} \\ V_1 - V_c + 0.4V_s &= 0.1 V_s + 0.4V_s = 0.5 V_s \\ &= 0.5 \times 0.01256 = 0.00628 \text{ m}^3\end{aligned}$$

Mass of steam at point of cut –off if it is dry and saturated,

$$\begin{aligned}m_1 &= \frac{V_1}{u_{g1}} = \text{specific volume of steam at 5 bar} = 0.375 \text{ m}^3/\text{kg} \\ \frac{0.00628}{0.375} &= 0.01674 \text{ kg/stroke}\end{aligned}$$

If  $m_s$  is the mass of steam supplied/stroke the missing quantity is given by

$(m_c + m_s) =$  missing quantity

$$0.002167 + m_3 - 0.01674 = 0.0072$$

$$m_3 = 0.02177 \text{ kg/stroke}$$

Mass of steam supplied per hour =  $0.02177 \times 60 \times 100 \times 2 = 261.24 \text{ kg/h}$

Specific steam consumption on I.P basis

$$= \frac{261.24}{30} = 8.708 \text{ kg/kWh}$$

Theoretical minimum possible steam/stroke will be if the steam at cut- off is dry and saturated Thus , minimum possible steam supplied/stroke.

$$= m_1 - m_c = 0.01674 - 0.002167 = 0.01457 \text{ kg/stroke}$$

Minimum steam that may be supplied/hour

$$= 0.01457 \times 60 \times 100 \times 2 = 174.84 \text{ kg/h}$$

Hence, minimum specific steam consumption on I.P. basis

$$\frac{174.84}{30} = \mathbf{5.828 \text{ kg/kWh}}$$

6. The cylinder of a non – condensing steam engine is supplied with steam at 11.5 bar. The clearance volume is  $\frac{1}{10}$  th of the stroke volume and the cut –off takes place at  $\frac{1}{4}$  th of the stroke. If the pressure the end of compression is 5.4 bar compute the value of mean effective pressure of the steam on he piston. Assume that expansion and compression are hyperbolic. The back pressure is 1.1 bar.

**Solution.**

Admission pressure,  $p_1 = 11.5$  bar  
 Clearance volume  $V_c = \frac{1}{10}$  th of stroke volume  $V_s$   
 Cut –off  $= \frac{1}{4}$  th of stroke  
 Pressure at the end of compression  $p_5 = 5.4$  bar  
 Back pressure  $p_b = p_3 = 1.1$  bar.

**Mean effective pressure , $p_m$ :**

The theoretical mean effective pressure, when clearance and compression are considered is given by

$$P_m(\text{th}) = p_1 \left[ \frac{1}{r} + \left( c \frac{1}{r} \right) \log_e \frac{c+1}{c + \frac{1}{r}} \right] - p_b \left[ (1-a) + (c+a) \log_e \left( \frac{a+c}{c} \right) \right]$$

$$r = \frac{1}{1/4} = 4 \text{ or } \frac{1}{r} = \frac{1}{4} \text{ and } c = \frac{V_s/10}{V_s} = 0.1$$

To find a (ratio of volume between points of compression and admission to the swept volume  $V_s$  applying hyperbolic law between the point of beginning and end of compression:

$$p_4 V_4 = p_5 V_5 \quad V_s = V_c \text{ and } p_4 = p_b = 1.1 \text{ bar and}$$

$$1.1 \times (V_c + a V_s) = 5.4 \times V_c \quad a = \frac{V_4 - V_c}{V_s}$$

$$a = \frac{5.4 V_c - 1.1 V_c}{1.1 V_s} \quad V_4 = V_{c+a} V_s$$

$$= \frac{5.4 V_c - 1.1 V_c}{1.1 V_s} = 0.39 \quad \text{Also } \frac{V_c}{V_s} = \frac{1}{10}$$

$$V_s = 10V_c$$

Now inserting various values in equation (i) we get

$$\begin{aligned} P_{m(th)} &= 11.5 \left[ \frac{1}{4} + 0.4 \frac{1}{4} \log_e \frac{0.1+1}{0.1+1/4} \right] \\ &\quad - 1.1(1-0.39) + (1+0.39) \log_e \left( \frac{0.39+0.1}{0.1} \right) \\ &= 11.5 \times 0.65 - 1.1 \times 1.388 = 5.95 \text{ bar} \end{aligned}$$

**7. Determine the actual m.e.p for a steam engine receives the steam at 6 bar cut-off takes when the piston has travelled 0.4 of the stroke in which clearance volume is 10% of the stroke. The back pressure and diagram factor are 1.03 bar and 0.7 of passively.**

**Given**

$$p_1 = 6 \text{ bar}$$

$$V_2 = V_1 = 0.4V_s$$

$$V_c = 10\% V_s$$

$$P_b = 1.03 \text{ bar}$$

$$DF = 0.7$$

**Find**

$$(p_m)_{\text{actual}}$$

$$\frac{V_3}{V_2} = r = \frac{V_c + V_s}{V_c + V_2 - V_1} = \frac{0.1V_s + V_s}{0.1V_s + 0.4V_s} = \frac{1.1V_s}{0.5V_s}$$

$$r = 2.2$$

$$(p_m)_{\text{theo}} = \frac{p_1 v_2 [1 + \ln(r)] - p_b v_3 - (p_1 - p_b) v_c}{V_3 - V_c}$$

$$6 \times 0.5 V_s [1 + \ln(2.2)] - 1.03 \times 1.1 V_s - \frac{(6 - 1.03) 0.1 V_s}{1.1 V_s - 0.1 V_s}$$

$$(p_m)_{\text{theo}} = 3.75 \text{ bar}$$

$$(p_m)_{\text{act}} = DF \times (p_m)_{\text{theo}}$$

$$= 0.7 \times 3.75$$

$$(p_m)_{\text{act}} = 2.61 \text{ bar}$$

8. A double acting single cylinder steam engine runs at 250 r.p.m and develops 30kW. The pressure limits of operation are 10 bar. cut-off is 40% of the stroke. The L/D ratio is 1.25 and the diagram factors is 0.75. Assume saturated steam at inlet, hyperbolic expansion and negligible effect of piston rod. Find:

- i. Mean effective pressure,
- ii. Cylinder dimensions and
- iii. Indicated thermal efficiency,

**Solution:**

Speed of the steam engine,  $N = 250$  r.p.m

power developed,  $P = 30$  kW

pressure limits of operation : 10 bar ( $p_1$ ), 1 bar ( $p_b$ )

Cut –off ratio  $r = \frac{1}{0.4} = 2.5$

L/D ratio = 1.25

Diagram factor,  $D.F = 0.75$

Condition of steam at inlet to the engine = dry saturated

- i. Mean effective pressure,**

$$P_m = D.F \left[ \frac{p_1}{r} (1 + \log_e r) - p_b \right]$$

$$= 0.75 \left[ \frac{10}{2.5} (1 + \log_e 2.5) - 1 \right] = 5.0 \text{ bar}$$

- ii. Cylinder dimensions and,**

Indicated power,  $I.P = \frac{10_{pm} LAN}{3} \text{ kW}$

or  $30 = \frac{10 \times 50 \times 1.25 D \times \frac{\pi}{4} D^2 \times 250}{3} = 4090.6 D^3$

or  $D^3 = \frac{30}{4090.6}$  or Cylinder dia.,  $D = \left( \frac{30}{4090.6} \right)^{\frac{1}{3}}$

Length of stroke  $L = 1.25 D = 1.25 \times 194 = 242.5 \text{ mm}$

iii. Indicated thermal efficiency,

$$\text{Mean flow rate of steam } \text{Ins} = \frac{\frac{\pi}{4} D^2 \times L \times \frac{1}{r} \times 2 \times n}{u_g}$$

$$\frac{\frac{\pi}{4} \times (0.194)^2 \times 0.2425 \times \frac{1}{2.5} \times 2 \times \frac{250}{60}}{0.194} = 0.1231 \text{ kg/s}$$

[ where  $u_g$  = specific volume of dry saturated steam at 10 bar = 0.164 m<sup>3</sup>/kg(From steam tables)

$$\therefore \text{ Indicated thermal efficiency, } \eta_{I.T} = \frac{I.P}{ms(h_1 - h_f)}$$

$$= \frac{30}{0.1231(2776.2 - 417.5)} = 0.1033 \text{ or } 10.33\%$$

[Where  $h_1$  = enthalpy of dry saturated steam at 10 bar = (2776.2 kJ/kg, and

$h_f$  = enthalpy of water at 1 bar = 417.5 kJ/kg(from steam tables)]

**9. A single cylinder double acting steam engine with 15 cm bore and 20 cm stroke is to develop 20 kW at 300 r.p.m. with cut-off occurring at 20% of stroke. Back pressure is 0.28 bar engine receives 222kg dry steam per hour. Neglect area of piston rod.**

**Solution:**

Engine bore,  $D = 15 \text{ cm} = 0.15 \text{ m}$

Stroke length,  $L = 20 \text{ cm} = 0.2 \text{ m}$

Speed of the engine  $N = 300 \text{ r.p.m}$

Power developed  $I.P = 20 \text{ kW}$

Diagram factor,  $D.F = 0.72$

Steam (dry) supplied per hour = 222 kg/h

Cut – off ratio,  $\frac{V_1}{V_2} = 0.2$

Indicated power,

$$I.P = \frac{p_m LAN \times 10}{3} \text{ kW}$$

$$20 = \frac{pm \times 0.20 \frac{\pi}{4} \times 0.15^2 \times 300 \times 10}{3} = 3.534 p_m$$

$$p_m = \frac{20}{3.534} = 5.659 \text{ bar}$$

$$(p_m)_{th} = \frac{p_m}{D.F} = \frac{5.659}{0.72} = 7.86 \text{ bar}$$

Also  $(p_m)_{th} = \frac{p_1}{r} [1 + \log_e] - p_b$

where  $r = (\text{ratio} = \frac{V_2}{V_1}) = \frac{1}{0.2} = 5$

$$7.86 = \frac{p_1}{5} [1 + \log_e 5] - 0.28$$

$$7.86 = 0.522 p_1 - 0.28 \text{ or } p_1 \frac{7.86 + 0.28}{0.522} = \mathbf{15.59 \text{ bar}}$$

**Indicated thermal efficiency,  $\eta_{th(i)}$ :**

From steam tables  $h_1 = 2793.4 \text{ kJ/kg}$  at 15.59 bar;  $h_{f2} = 282.7 \text{ kJ/kg}$  at 2.8 bar

$$\begin{aligned} \text{Heat supplied to steam} &= \frac{222}{3600} (h_1 - h_{f2}) = \frac{222}{3600} (2791.4 - 282.7) \\ &= 154.83 \text{ KJ/s} \end{aligned}$$

$$\eta_{th(I)} = \frac{20}{154.83} = 0.1292 \text{ or } 12.92\%$$

- 10. A steam engine received steam at a pressure of 13.6 bar absolute and the clearance ratio is 1/10 cut-off takes place at 0.25 of the stroke. The back pressure is 1.15 bar (abs) Draw the type the indicator diagram and calculate the mean effective pressure take diagram factor as 0.80. If cylinder dimensions are 203 mm and 254 mm calculate Indicated power developed in the engine**

**Given**

$$p_1 = 13.6 \text{ bar}$$

$$\frac{V_c}{V_s} = k = \frac{1}{10} = 0.1$$

$$V_2 = V_1 = 0.25V_s$$

$$P_b = 1.15 \text{ bar}$$

$$DF = 0.80$$

$$D = 0.203 \text{ m}$$

$$L = 0.254 \text{ m}$$

**Find**

i.  $(p_m)$  actual

ii. IP

**Solution:**

$$\text{Cut off ratio} = \frac{V_2 - V_1}{V_s} = m$$

$$V_2 - V_1 = 0.25 V_s$$

$$\therefore M = \frac{V_2 - V_1}{V_s} = 0.25$$

$$k = 0.1$$

$$\therefore (p_m) = p_1 M + p_1 (k+M) \ln \left[ \frac{k+1}{k+M} \right] - P_b$$

$$= 13.6 \times 0.25 + 13.6(0.25+0.1) \ln \left[ \frac{0.1+1}{0.1+0.25} \right] - 1.15$$

$$= 3.4 + 5.4507 - 1.15$$

$$(p_m)_{\text{theo}} = 7.7007 \text{ bar}$$

$$(p_m)_{\text{act}} = (p_m)_{\text{theo}} \times DF$$

$$= 7.7007 \times 0.80$$

$$(p_m)_{\text{act}} = 6.16 \text{ bar}$$

$$\therefore IP = \frac{100 p_m L A N_w}{60} \text{ KW}$$

$$N_w = N = 200 \text{ rpm (Assume)}$$

$$IP = \frac{100 \times 6.16 \times 0.254 \times \pi (0.203)^2 \times 200}{60 \times 4}$$

$$IP = 16.88 \text{ kW}$$



11. The following were obtained during test double acting steam engine:

Indicated mean effective pressure = 2.5 bar : R.P.M = 104: Bore = 250 mm : stroke = 300mm :Net brake load =1150 N :effective brake drum diameter = 1.65 m The steam is supplied at 7 bar and is dry and saturated. The condenser pressure = 0.077 bar: condenser temperature = 22°C and condensate quantity = 3.3 kg/min

Determine

1. Indicated power
2. brake power
3. mechanical efficiency: and
4. brake thermal efficiency

**Solution:**

Given:  $p_a = 2.5$  bar:

$N = 104$  r.p.m;

$D = 250$  mm = 0.25 m ;

$L = 300$  mm = 0.3 m;

$(W-S) = 1150$  N;

$D_1 = 1.65$  m;

$p_1 = 7$  bar;

$p_b = 0.007$  bar;

$t = 22^\circ\text{C}$  ms = 3.3 kg/min

### 1. Indicated power

We know that area of piston

$$A = \frac{\pi}{4} \times D^2 = \frac{\pi}{4} (0.25)^2 = 0.0491 \text{ m}^2$$

∴ Indicated power

$$I.P = \frac{200 p_a L A N}{60} = \frac{200 \times 2.5 \times 0.3 \times 0.0491 \times 104}{60} = 12.8 \text{ kW}$$

### 2. Brake power

We know that brake power

$$B.P = \frac{(W - S) \pi D_1 N}{60} = \frac{1150 \times \pi \times 1.65 \times 104}{60} = 10.33 \times 10^3 \text{ W}$$
$$= 10.33 \text{ kW}$$

### 3. Mechanical efficiency

We know that mechanical efficiency,

$$\eta_m = \frac{B.P}{I.P} = \frac{10.33}{12.8} = 0.807 \text{ or } \mathbf{80.7\%}$$

### 4. Brake thermal efficiency

From steam tables corresponding to a pressure of 7 bar, we find that

$$h_1 = h_g = 2762 \text{ kJ/kg} \quad \dots\dots\dots(\text{For dry saturated steam})$$

and corresponding to a condenser pressure of 0.07 bar,

$$h_{fb} = 163.4 \text{ kJ/kg}$$

we know that thermal efficiency

$$= \frac{BP \times 60}{m_s (h_1 - h_{fb})} = \frac{10.33 \times 60}{3.3(2762 - 163.4)} = 0.0723 \text{ or } \mathbf{7.23\%}$$

**MEEC-402\PMEEC-302 HEAT ENGG I**

**NOVEMBER 2014**

**UNIT- III**

5. Explain the working principle of four stroke petrol engine with neat sketches.

6. Discuss with the help of suitable sketches the following:

a)Wet sump lubrication (b) Dry sump lubrication

**UNIT- IV**

7. Describe the phenomenon detonation or knocking in SI engine. How can it be controlled?

8. Explain the working principle of magneto ignition system with neat sketch, also with advantages and disadvantages.

**UNIT –V**

9. The following readings were taken during the test of a single cylinder four stroke oil engine:

Cylinder diameter =250mm

Stroke length =400mm

Gross mep =7 bar

Pumping mep =0.5 bar

Engine speed = 250 rpm

Net load on the brake 1080 N.

Effective diameter of the brake 1.5 m

Calorific value of the fuel=44300 kJ /kg.

Calculate: a) indicated power b) brake power c) mechanical efficiency

d) Indicated thermal efficiency.

**10. in a test of four cylinder, four stroke diesel engine 75mm bore and 100mm stroke, the following results were obtained at full throttle at a particular constant speed and with a fixed setting of fuel supply 6.0 kg/hr:**

BP with all cylinder:

BP with cylinder no.1 cut out =11. kW

BP with cylinder no.2 cut out =11.03 kW

BP with cylinder no.1 cut out =10.88 kW

BP with cylinder no.1 cut out =10.66 kW

Calorific value of the fuel =83600 kJ

Clearance volume =0.0001m<sup>3</sup>.

Calculate:

- (a) Mechanical efficiency (b) indicated thermal efficiency.
- (b) Air standard efficiency.

UNIT III

Explain the working principle of four stroke petrol engine with neat sketches

FOUR STROKE SPARK IGNITION ENGINE

In 1862, Beau de Rochas, a French Engineer had proposed a sequence of operation that is even today, typical of most SI engines, figure 3.

(a) **Suction Process** - In order to start the engine the crankshaft is rotated either by hand or by a starter motor causing the connecting rod to draw the piston downwards from TDC to BDC and the inlet valve opens to draw a homogeneous combustible mixture of air and fuel through the intake manifold inside the cylinder, figure 4(a). The air and fuel are mixed together in a carburetor prior to the entry to the engine cylinder and the inlet valve (IV) communicates with the carburetor through a throttle valve. As an alternative to the carburetor, the fuel can also be injected into the intake manifold or the inlet port with the help of injectors operated either mechanically or electronically. During the suction process, the pressure inside the cylinder is lower than the ambient pressure by an amount which depends upon the speed of the engine and the opening of the throttle valve.

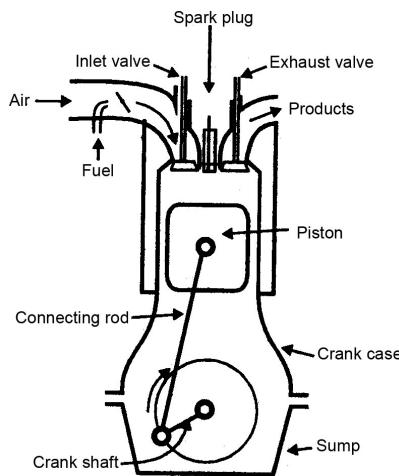

Figure 4 A typical SI engine.

**Compression Process** -when the piston moves upward from BDC to TDC figure 4b (the stroke described by the piston) both the inlet the outlet valves should remain closed. The fresh charge sucked inside during the previous stroke of the piston, mixes with the residual gases present in the clearance space of the cylinder and the mixture is compressed and its pressure and temperature increases. The pressure rise depends upon the compression ratio and in common SI engines, the ratio varies between 6 to 11 and the pressure at the end of compression is about 0.6 to 0.9 MPa. During the compression process, a small amount of heat energy is transferred to the surroundings through the piston, cylinder head and cylinder walls but its effect is very modest.

**Ignition and Expansion Process** - Near the end of the second or compression process (between 10 and 40 crank angle degrees before TDC) there is an electric discharge across the spark plug to initiate the combustion process and consequently the homogeneous air fuel mixture burns. The combustion is completed within a few milliseconds and it is assumed that combustion takes place at constant volume and during that period the piston is practically at rest and the liberated heat energy rapidly raises the pressure and temperature of the gases. The expanding gases force the piston to descend downwards (the third stroke) describing the expansion process figure 4c. During this operation, both the valves are closed,

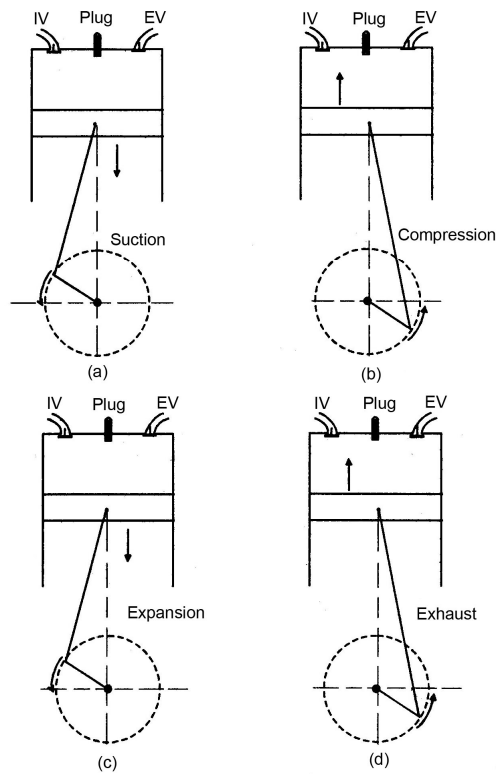

Figure 4 Sequence of operation of a 4-stroke SI engine.

**Exhaust Process** - The exhaust valve opens near the end of the expansion process or the power stroke and the burned gases are pushed out of the cylinder by the ascending piston (Figure 4d). The exhaust valve (EV) communicates with the silencer through which the burned gases are discharged to the atmosphere. The pressure inside the engine cylinder is a little more than the ambient pressure and its value depends upon the resistance to flow offered by the exhaust valve and silencer

**Describe the phenomenon detonation or knocking in SI engine. How can it be controlled?**

**Detonation or knock**

In spark ignition engine a small focus of combustion is formed between spark plug electrode and its spreads over the combustible mixture with a rather definite flame front which separates the fresh mixture from the products of combustion. Heat release due to combustion increases the temperature and consequently the pressure of the burned part of the mixture above those of the unburned mixture. In order to affect pressure equalization the burned part of the mixture will expand and compress the unburned mixture adiabatically thereby increasing its pressure and temperature. This process will continue as flame front propagates through the mixture and the temperature and pressure of the unburned mixture goes on increasing. At a certain instant when the flame front has reached (fig 1.2) the unburned charge reaches its self – ignition .

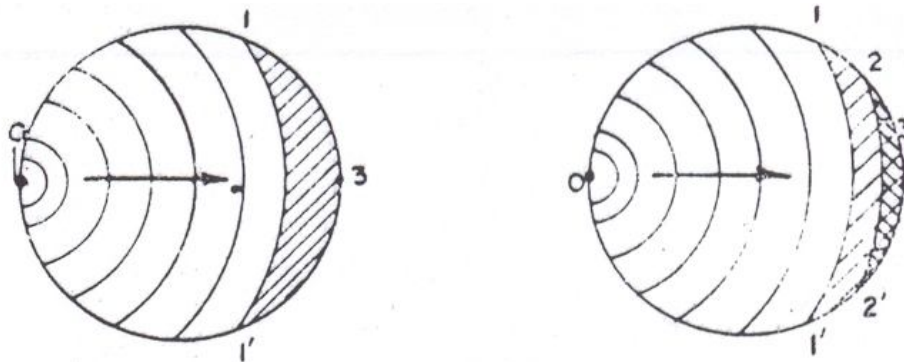

(a) Normal combustion.

(b) Detonating combustion.

*flame propagation in normal and detonating combustion*

*(Schematic representation).*

temperature depending on its pressure and composition. The temperature and the pressure of this charge go on increasing as the flame front proceeds. This charge, commonly known as end gas will undergo the pre-ignition reactions over a period called the

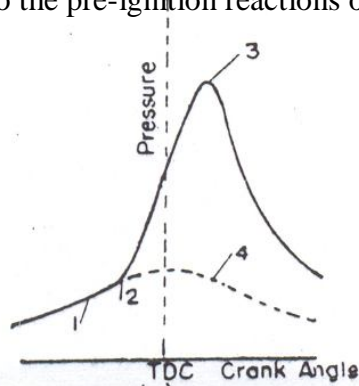

(a) Normal combustion

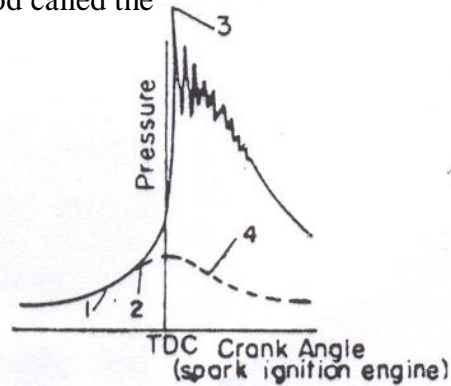

(b) Detonating combustion

***Pressure crank angle diagram of normal and detonating***

***Combustion in spark ignition engine.***

ignition lag or ignition delay. During this period the flame front generally propagates through this charge and combustion is completed before the ignition lag period is over. In some cases with very low compression temperature, the unburnt mixture does not attain the self ignition temperature even when the flame spreads over the last portion of charge that is when combustion is complete. In both cases the combustion is normal. However in some special cases the flame front can travel only to the position when ignition lag is over and all the charge ahead is ready for ignition. In actual case the mixture is never perfectly homogeneous in temperature. Flames, therefore, appear at multiple foci and then spread to adjacent area with high velocity, igniting the remaining unburnt mixture. When the ignition spreads with a very high velocity the portion of the mixture, where pre-flame reaction is nearly complete, burns with in a very short time. Nearly instantaneously burning of mixture ahead of flame front results in a high local pressure in this mixture and excites resonant vibration of gases inside the cylinder. The pressure waves are formed and they travel through the gases. They strike against the wall and are reflected back and forth producing metallic sound. This process of completion of combustion as a result of auto ignition of end gas accompanied by propagation of pressure waves which produce metallic sound due to called detonating combustion or detonation in spark ignition engine. Pressure crank angle



diagrams of detonating combustion figure Shows pressure oscillations at the end of combustion with gradually diminishing pressure peaks. The frequency of these pressure oscillations is the same as fundamental frequency of the knocking sound. It depends on the velocity of the pressure wave and the distance between consecutive reflections from the wall of combustion chamber.

### **Pressure effects**

- (i) A higher compression ratio, which increases the pressure and temperature of the last portion of the charge to burn
- (ii) An increase in inlet manifold pressure due to more throttle opening or due to supercharging.

### **Temperature effects**

- (i) A higher mixture temperature due to manifold heating higher atmospheric temperature, super charging or increased compression ratio.
- (ii) A higher temperature of cooling water in the jacket which reduces cooling of the last portion of the charge to burn.

### **Time effects**

- (i) A lower value of ignition delay due to use of lower octane number fuel
- (ii) A lower value of flame velocity due to lower r.p.m of the engine or due to lower intensity of turbulence caused by combustion chamber design.

### **FACTORS AFFECTING KNOCK**

1. Decreasing the compression ratio or reducing the inlet pressure
2. Decreasing the inlet air temperature
3. Decreasing coolant inlet air temperature
4. Retarding spark timing
5. Decreasing the load
6. Increasing octane rating of the fuel

7. supplying rich or lean mixtures
8. Increasing the humidity of the entering air
9. Stratifying the mixture so that the end gas is less reactive
10. Increasing the turbulence of the mixture and thus increasing the flame speed.

**Discuss with the help of suitable sketches the following:**

**a)Wet sump lubrication (b)Dry sump lubrication**

## ENGINE LUBRICATING SYSTEMS

Engine lubrication system means lubrication of main engine parts like main bearings, connecting rod bearings, wrist pins, camshaft bearings and cams, cylinder walls, valves and timing drive. Equipments like starter, generator, water pump and distributor are separately lubricated. The engine lubrication system circulates oil from a common sump or reservoir at the bottom of the crank case and may be called Wet sump lubrication. This can be classified as

- (i) Full pressure system
- (ii) Splash system and
- (iii) Modified splash system.

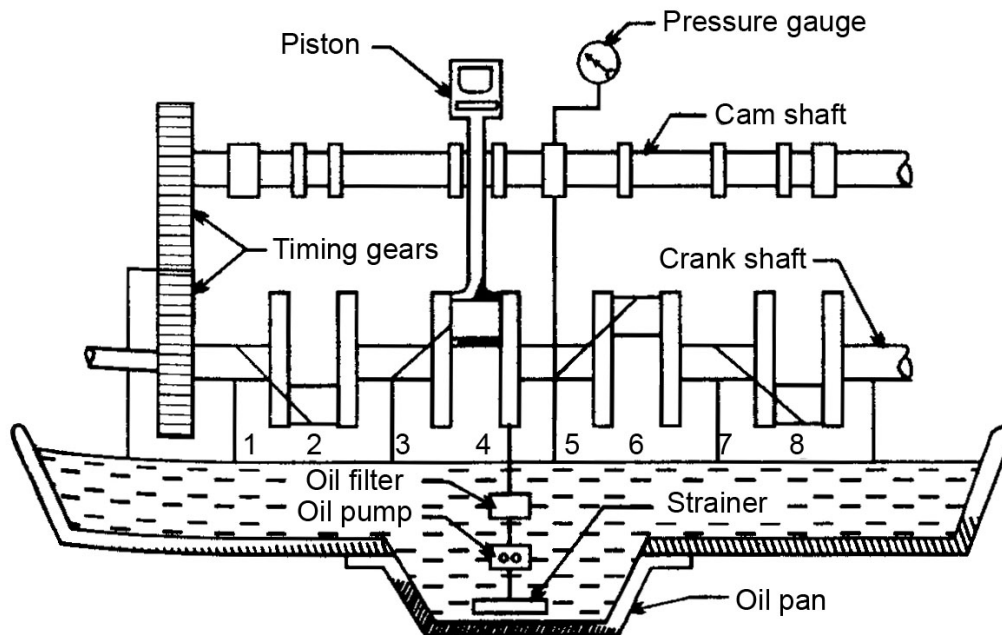

*Figure 19. Full pressure lubricating system.*

Full pressure system has been shown schematically, figure 19. Oil is forced through different parts under pressure by a geared pump to most of the various rotating and reciprocating parts. Oil enters the connecting rod bearings and crankshaft through drilled passages. A nozzle is sometimes placed on the upper end of the connecting rod to spray oil, as a coolant, on the underside of the piston crown (as in diesel engine). Overhead valve engines have an oil line leading to a hollow rod which supports the rocker arm. Oil can then flow through the rocker arms, to valve stems and tappets and down to the valve guides. This system is best suited for large engines.

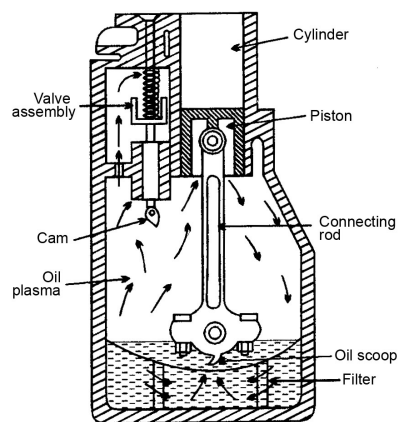

*Figure 20. Splash system for a single cylinder engine*

Small engines usually have a splash system, shown in figure 20. The level of oil is maintained at a particular level in the sump. The connecting rod is supplied with dippers on the end and they splash the oil on the various parts as they travel through oil troughs at the bottom of the stroke.

A pump is usually employed to carry the oil to the troughs. Excess oil supplied falls back into the sump under the action of gravity.

Modified splash system is a combination of the full pressure and splash system. The main and crankshaft bearings are lubricated on the principles of full pressure system and the connecting rod bearings are lubricated by means of dippers as shown in Figure 21.

Since it is not possible even with the finest gauge to filter all the minute particles of grit and abraded metal which cause wear of bearings, it is essential to have in the oil circuit adequate filters of large total area for the removal of all dangerous abrasive materials. Therefore, two filters in the circuit one before the pump and the other after the pump are provided. The gear pump produces the required pressure in the system and is driven by the camshaft. An oil pressure gauge is provided to indicate satisfactory oil supply.

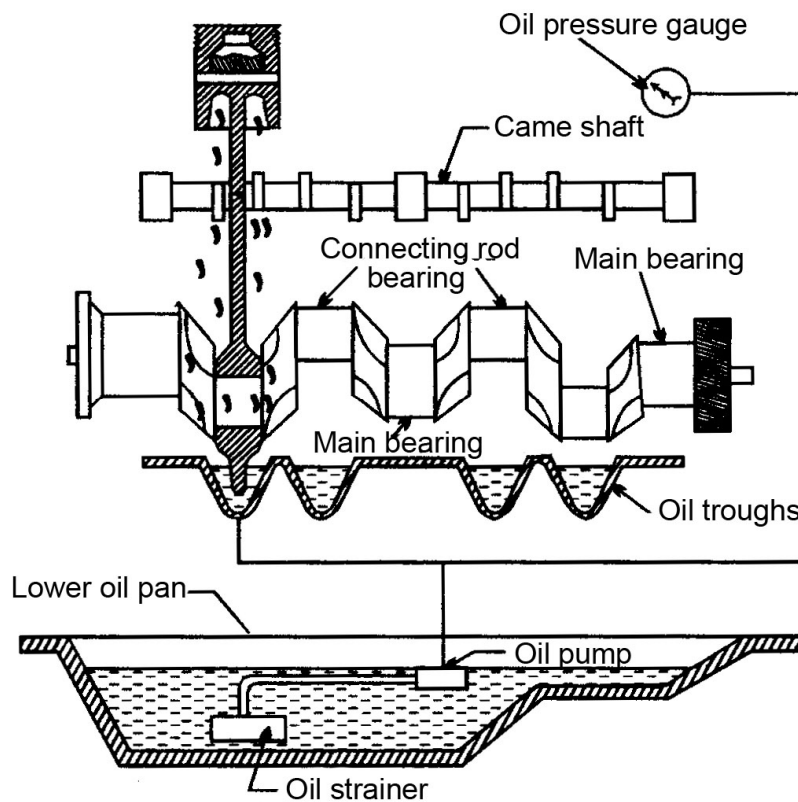
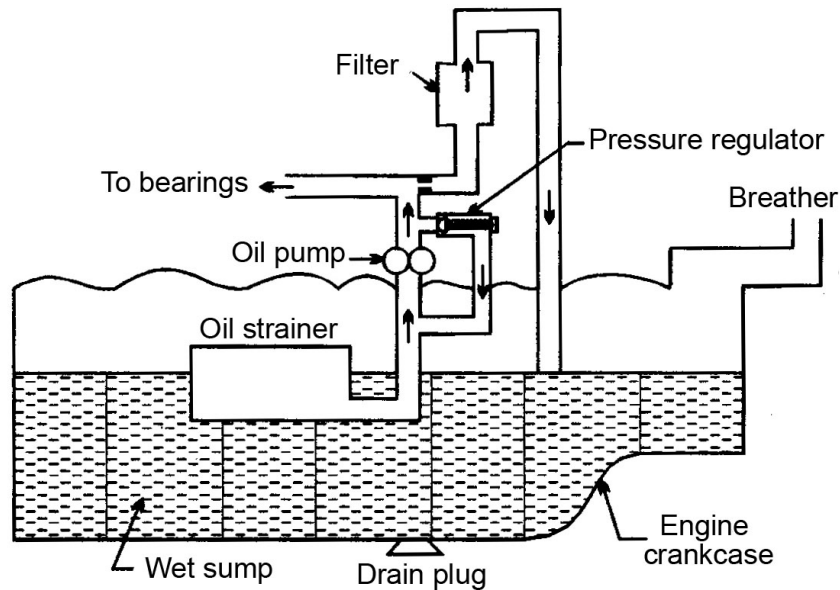

Figure 21. Splash system for a four cylinder engine.

Mist Lubrication System- In most of the two-stroke engines, the charge enters the crankcase through reed valve while the piston is describing the inward stroke (moving towards TDC) and is compressed in the crankcase when the piston describes the expansion stroke. Thus, two-stroke engines are not suitable for crankcase lubrication.



*Figure 22. Wet sump lubrication system*

The full pressure or forced system of lubrication can be either Wet sump or the dry sump system. In the wet sump system (Figure 22) there is only one pump which draws its oil from the bulk supply contained in the sump formed in the lower half of the crank case.

Therefore 2 to 3 percent lubricating oil (a fuel/oil ratio of 40 to 50:1 is the optimum for good performance) is mixed with the fuel (gasoline) in fuel tank. When the mixture passes through the carburetor, the gasoline, being more volatile, vapourizes and mixes with air. The oil which is less volatile enters the crankcase as a mist and goes to the cylinder for lubrication. The oil impinging on the crankcase walls lubricates the main and connecting rod bearings. Some oil enters the engine cylinder with the vapourized fuel and lubricates the piston, piston rings and cylinder.

**Explain briefly working principle of simple carburetor?**

## **SIMPLE CARBURETOR**

The simple plain carburetor shown in figure 9 works on the basic principles underlying all carburetors. All modern commercial carburetors have evolved from this simple plain-tube

carburetor. The basic components are: a venturi, a fuel nozzle with metering orifice, a fuel reservoir with a float, a throttle and a choke. When the piston describes the suction stroke, there is a depression in the induction system and the air before entering the engine cylinder, enters the intake section of the carburetor through the air cleaner which removes the Suspended particles in air. The air then enters the venturi which is a convergent divergent nozzle, because this shape of the venturi has the minimum pressure loss. Since the same quantity of air has to pass through every point of this channel of varying cross-sectional area, the velocity of air at the throat is maximum and the pressure is minimum (maximum depression) at that section.

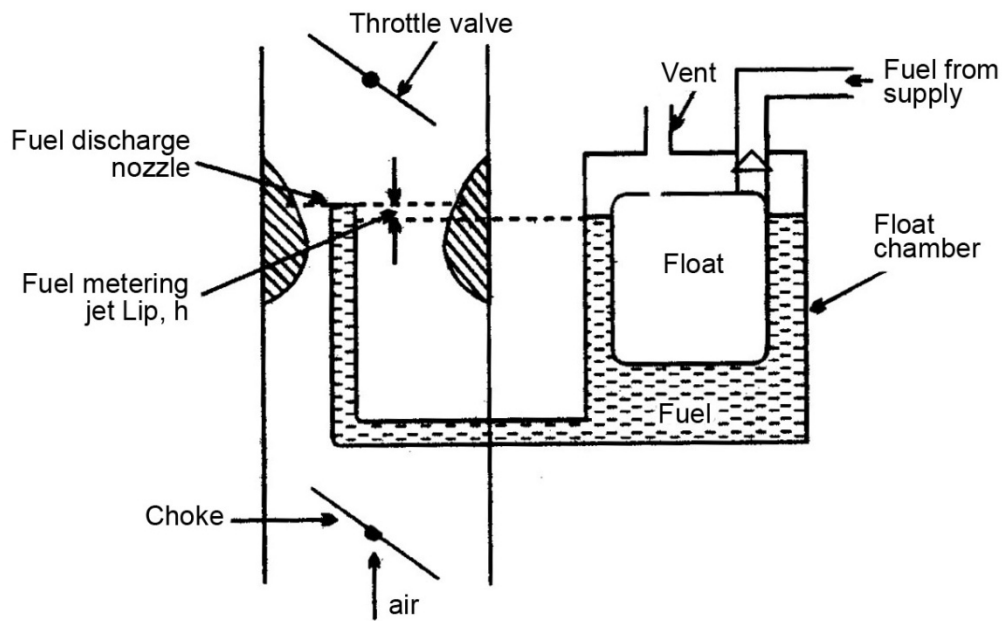

*Figure 9. Schematic diagram of a simple float type carburetor.*

The level of fuel in the reservoir (also called the float chamber) is maintained at a constant level by the float. A small vent-hole is provided in the lid of the float chamber to ensure that the free surface of the fuel is always subjected to atmospheric pressure. Since the pressure inside the float chamber is always atmospheric and is greater than the pressure at the throat of the venturi, i.e., at the fuel discharge nozzle tip, the fuel flows through the calibrated orifice to the fuel discharge nozzle. A fuel pump is used to pump fuel from the fuel storage tank to the float chamber of the carburetor through the needle valve. When the level of the fuel in the float chamber falls below a fixed level, the needle valve opens the fuel passage admitting more fuel in the float chamber. With the increase in the level of the fuel inside the float chamber, the float

risers and closes the fuel passage, thus maintaining a constant level of fuel in the float chamber. The fuel comes out of fuel discharge nozzle like a stream of liquid droplets. These droplets disintegrate into smaller droplets while moving with the air stream and during this process of disintegration fuel vapourizes from its droplet surfaces. The fuel-air mixture flows through the diverging section of the venturi where the flow decelerates and some pressure recovery occurs.

It has been found that the vapourization of fuel particles inside the carburetor is very limited and the major portion of the fuel vaporizes in the intake manifold. Since fuel droplets may also enter the cylinder in the liquid form and these get evaporated and mix with air during suction and compression stroke of the piston. The degree of atomization inside the carburetor depends upon the relative velocity of air and fuel streams and the fuel properties (density, surface tension etc.).

After the venturi, air fuel mixture flows past the throttle plate before entering the intake manifold. The speed and power of the engine is controlled by the use of this throttle plate which is a form of a damper placed between the mixing chamber (venturi) and the intake manifold. With the opening or closing of the throttle, the obstacle to the flow of mixture increases or decreases. When the throttle is closed, a very small amount of air and fuel will enter the engine cylinder and the pressure inside the engine cylinder during the suction stroke of the piston would be much lower than the atmospheric pressure. This would result in a lower pressure at the end of compression stroke and also after combustion. Since the pressure exerted on the piston and the turning effort applied on the crankshaft depends upon the quantity of fuel burned in each cylinder per cycle, the speed of the engine would also be lower during the closed throttle position. When the throttle is gradually opened, the speed of the engine will gradually increase and thus, the speed of the engine is controlled by opening or closing the throttle. If the engine is connected to a load, the speed of the engine can be maintained constant by varying the throttle position with respect to load.

The other basic component of the carburetor is the choke inserted in the air-intake passage of the carburetor. The choke enables the engine to receive an additional amount of fuel (a rich mixture) for starting the engine under cold conditions. By closing the choke, the quantity

of air flowing through the venturi is drastically reduced and the suction of the engine exerts directly on the fuel discharge nozzle to cause fuel to flow.

In the simple carburetor, shown in Figure 8.2, the fuel flows from the float chamber through the fuel discharge nozzle because of the pressure difference between the atmospheric pressure in the float chamber and the pressure at the throat. And, this pressure difference has to overcome the surface tension effects also at the nozzle exit. When the speed of the engine is low, i.e., when the throttle is almost closed, the quantity of air flowing through the venturi is very small and the vacuum created at the venturi is insufficient to draw fuel into the air stream. When the speed of the engine increases, the quantity of air flowing through the venturi increases and this creates a large vacuum at the throat. Therefore, a proportionally greater amount of fuel is sprayed into the air stream. Thus a simple carburetor has a tendency to supply a rich mixture ( $\phi > 1$ ) at higher speeds of the engine and a weak mixture ( $\phi < 1$ ) at lower speeds.

### **Different types of combustion chambers used in CI engines ?**

#### **COMBUSTION CHAMBERS**

The most important function of the CI combustion chamber is to provide proper mixing of fuel and air in a short time. In order to achieve this an organized air movement called the air swirl is provided to produce high relative velocity between the fuel droplets and the air. The fuel is injected into the combustion chamber by an injector having single or multihole orifices. The increase in the number of jets reduces the intensity of air swirl needed.

CI engine combustion chambers are classified into two categories

**Direct injection (DI) type:** This type of combustion chamber is also called an open combustion chamber. In this type the entire volume of the combustion chamber is located in the main cylinder and the fuel injected into this volume.

**Indirect –injection (IDI) type:** the combustion space is divided into two parts one part in the main cylinder and other part in the main cylinder. The fuel injection is effected usually into that part of the chamber located in the cylinder head. These chambers are classified further into



Swirl chamber in which compression swirl is generated

Pre combustion chamber in which combustion swirl is induced

Air cell chamber in which both compression and combustion swirl are induced

**Direct –injection chambers:**

An open combustion chamber is defined as one in which the combustion space is essentially a single cavity with little restriction from one part of chamber to the other and hence with no large difference in pressure between the parts of the chamber during the combustion process. There are many designs of open chambers some of which are shown .

**Shallow depth chamber:** The depth of cavity provided in the piston is quiet small. This chamber is usually adopted for large engines running at low speeds. The cavity diameter is very large the squish is negligible.

**Hemispherical chamber:** This chamber also gives small squish .However the depth to diameter ratio for a cylindrical chamber can be varied to give any desired squish to give better performance.

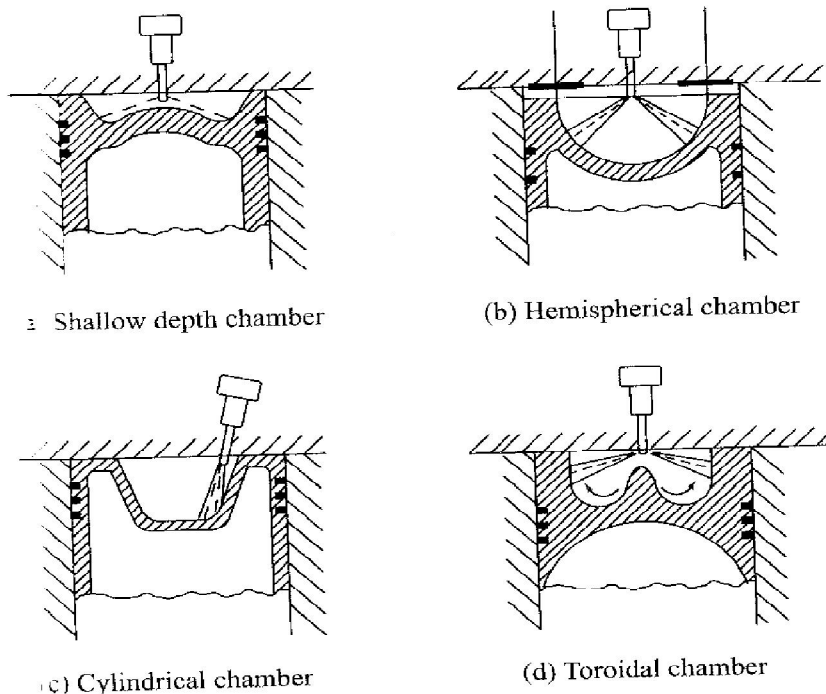

**Fig .Open combustion chambers**

### **Cylindrical chamber:**

This design is attempted in recent diesel engines. This is a modification of cylindrical chamber in the form of a truncated cone with base angle of  $30^\circ$ . The swirl was produced by masking the valve for nearly  $180^\circ$  of circumference. Squish can also be varied by varying the depth

### **Toroidal chamber**

The idea behind the shape is to provide a powerful squish along with the air movement similar to that of the familiar smoke ring within the toroidal chamber. Due to the powerful squish the mask needed on inlet valve is small and there is better utilization of oxygen. The cone angle of spray is  $150^\circ$  to  $160^\circ$ .

**2.3.2 Indirect –injection chambers:** A divided combustion chamber is defined as one in which the combustion space is divided into two or more distinct compartments connected by restricted passages. This creates considerable pressure differences between them during the combustion.

### **Swirl chamber:**

It consists of a spherical shaped chamber separated from the engine cylinder and located in the cylinder head. Into this chamber about 50% of air is transferred during the compression stroke.

A throat connects the chamber to the cylinder which enters the chamber in a tangential direction so that the air coming into this chamber is given a strong rotary movement inside the swirl chamber and after combustion the products rush back into the cylinder through the same throat at much higher velocity.

This causes considerable heat loss to the walls of the passage which can be reduced by employing a heat insulated chamber. In this type of combustion chambers even with heat insulated passage the heat loss is greater than that in an open combustion chamber which employs induction swirl

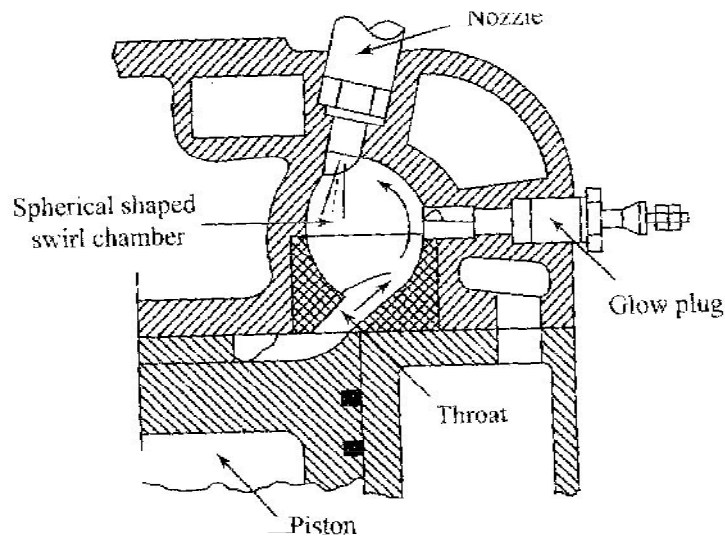

**Fig .Ricardo swirl chamber comet mark II**

**Precombustion chamber:**

A typical precombustion chamber consists of an anti chamber connected to the main chamber through a number of small holes. The precombustion chamber is located in the cylinder head and its volume accounts for 40% of total combustion space. During the compression stroke the piston forces the air into the precombustion chamber.

The fuel injected into the prechamber and the combustion is initiated. The resulting pressure rise forces the flaming droplets together with some air and their combustion products to rush out into the main cylinder at high velocity through the small holes.

Thus it creates both strong secondary turbulence and distributes the flaming fuel droplets throughout the air in the main combustion chamber where bulk of combustion takes place. About 80% of energy is released in main combustion chamber

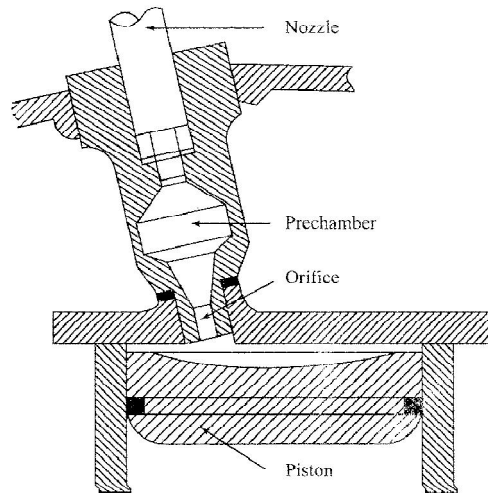

**Fig. Pre combustion chambers**

**Air cell chamber:** The clearance volume is divided into two parts one in the main cylinder and other called the energy cell. The energy cell is divided into two parts major and minor which are separated from each other and from the main chamber by narrow orifice. A pintle type on nozzle injects the fuel across the main combustion chamber space towards the open neck of the air cell.

During compression the pressure in the main chamber is higher than that inside the energy cell due to restricted passage area between the two. At the TDC the difference in the pressure will be high and air will be forced at high velocity through the opening into the energy cell and this moment the fuel injection starts. Combustion starts initially in the main chamber where temperature is comparatively higher but the rate of burning is very slow due to the absence of any air motion. In energy cell the fuel is well mixed with air and high pressure is developed due to heat release and hot burning gases blow out through the small passage into the main chamber.

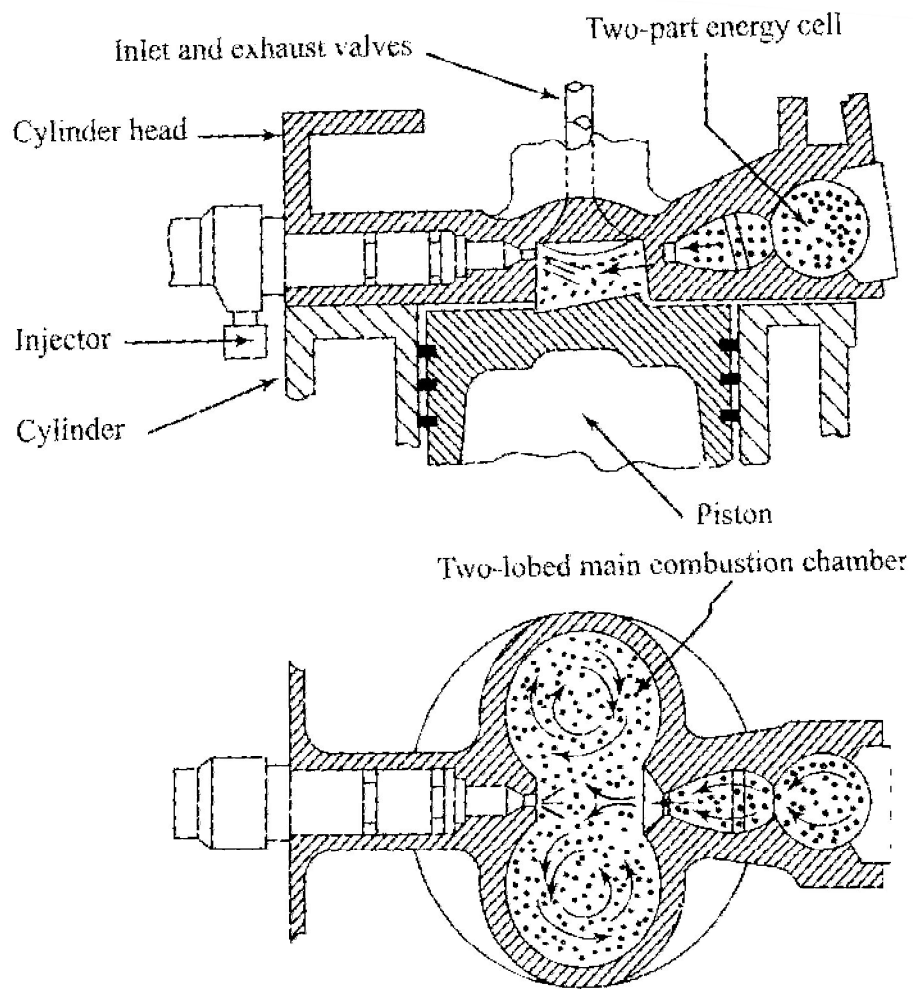

**Fig . Lanova air-cell combustion chambers**

This high velocity jet produces the swirling motion in the main chamber and thereby thoroughly mixes the fuel with air resulting in complete combustion. The design is not suitable for variable speed operation as the combustion induced swirl has no relationship to the speed of the engine. The energy cell is designed to run hot, to reduce ignition lag.

**Different types of combustion chambers in SI engines?**

**COMBUSTION CHAMBERS:**

Different types of combustion chambers for SI engines are developed over a time. Brief descriptions of those combustion chambers are given below.

**T-Head type:**

It is used in early stage of engine development. Since the distance along the combustion chamber is very long , knocking tendency is high in this type of engines. This configuration provides two valves on either side of the cylinder requiring two camshafts.

**L-Head type:**

It is a modification of L type which provides the two valves on the same side of the cylinder and the valves are operated by a single camshaft. The main objective of the Ricardo's turbulent head design are to obtain fast flame speed and reduced knock.

The main body of the combustion chamber is concentrated over the valves leaving a slightly restricted passage communicating with the cylinder thereby creating the additional turbulence during the combustion stroke.

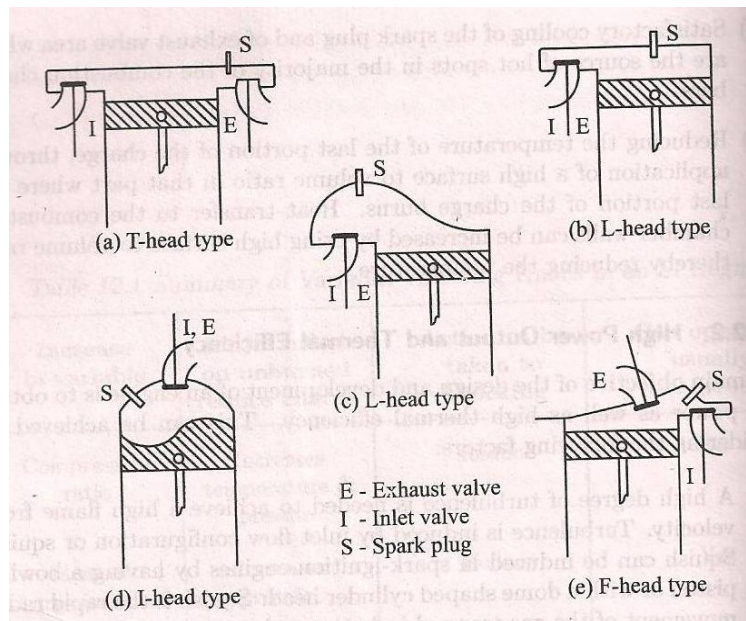

**Fig. Examples of typical combustion chamber**

### **I-Head type or Overhead valve:**

Both the valves are located on the cylinder head. The overhead valve engine is superior to the side valve at high compression ratios. Some important characters are

Less surface to volume ratio and therefore less heat loss

Less flame travel length and hence greater freedom from knock

Higher volumetric efficiency from larger valves

Confinement of the thermal failures to the cylinder head by keeping the hot exhaust valve in the head instead of the cylinder block

### **F-Head type:**

The valve arrangement is a compromise between L head and I head types. Combustion chambers in which one valve is in the cylinder head and other in cylinder block are known as F head type combustion chambers. Modern F head engines have exhaust valve in the head and inlet valve in the cylinder block.

**Explain with the help of Pressure-crank angle diagram different stages combustion in CI engines?**

### **STAGES OF COMBUSTION IN CI ENGINES**

The combustion in a CI engine is considered to be taking place in four stages. It is divided into the ignition delay period, the period of rapid combustion, the period of controlled combustion and the period of after-burning. The details are explained below.

#### **Ignition Delay Period**

The ignition delay period is also called the preparatory phase during which some fuel has already been admitted but has not yet ignited. This period is counted from the start of injection to the point where the pressure-time curve separates from the motoring curve indicated as start of combustion in figure.

The delay period in the CI engine exerts a very great influence on both engine design and performance. It is of extreme importance because of its effect on both the combustion rate and knocking and also its influence on engine starting ability and the presence of smoke in the exhaust.

The fuel does not ignite immediately upon injection into the combustion chamber. There is a definite period of inactivity between the time when the first droplet of fuel hits the hot air in the combustion chamber and the time it starts through the actual burning phase. This period known as the ignition delay period. In fig the delay period is shown on pressure crank angle diagram between points (a) and (b). point a represents the time of injection and point b represents the time at which the pressure curve first separates from the motoring curve. The ignition delay period can be divided into two parts, the physical delay and the chemical delay.

#### **Physical delay:**

The physical delay is the time between the beginning of injection and the attainment of chemical reaction conditions. During this period the fuel is atomized, vaporized, mixed with air and raised to its self-ignition temperature.

This physical delay depends on the type of fuel, i.e., for light fuel the physical delay is small while for heavy viscous fuels the physical delay is high.

The physical delay is greatly reduced by using high injection pressures, higher combustion chamber temperatures and high turbulence to facilitate breakup of the jet and improved evaporation.



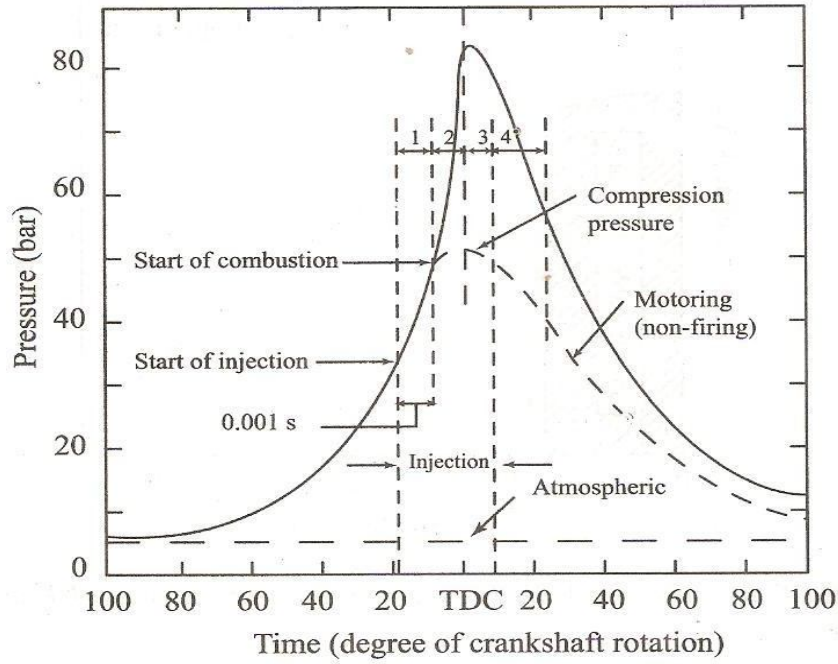

**Fig 2.1 Stages of combustion in CI engine**

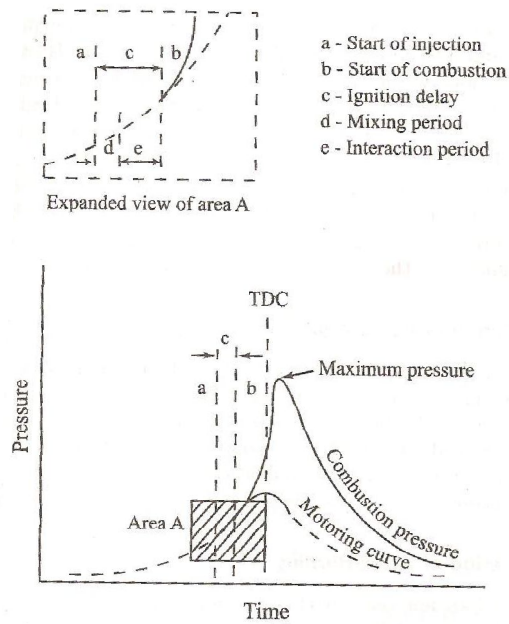

**Fig . Pressure time diagram illustrating ignition delay**

### **Chemical delay:**

During the chemical delay, reactions start slowly and then accelerate until inflammation or ignition take place. Generally the chemical delay is larger than physical delay. However it depends on the temperature of surroundings and at high temperatures the chemical reactions are faster and the physical delay becomes longer than the chemical delay. It is clear that the ignition lag in SI engine is essentially equivalent to the chemical delay for the CI engine. In most CI engines the ignition lag is shorter than the duration of injection.

### **Period of rapid combustion:**

The period of rapid combustion also called the uncontrolled combustion is that phase in which the pressure rise is rapid. During the delay period the droplets have had time to spread over a wide area and fresh air is always available around the droplets. Most of the fuel admitted would have evaporated and formed a combustible mixture with air. By this time the pre flame reactions would have also been completed. The period of rapid combustion is counted from end of delay period. The rate of heat release is maximum during this period. The pressure reached during the period of rapid combustion will depend on the duration of the delay period.

### **Period of controlled combustion:**

The rapid combustion period is followed by the third stage the controlled combustion. The temperature and pressure in the second stage is already quite high. Hence the fuel droplets injected during the second stage burn faster with reduced ignition delay as soon as they find the necessary oxygen and further pressure rise is controlled by the injection rate. The period of controlled combustion is assumed to end at maximum cycle temperature.

Period of after burning: combustion does not cease with the completion of the injection process. The unburnt and partially burnt fuel particles left in the combustion chamber start burning as soon as they come in contact with the oxygen. This process continues for a certain period called the after burning period. Usually this period starts from the point of maximum cycle temperature and continues over a part of expansion stroke. Rate of after burning depends on the velocity of diffusion and turbulent mixing of unburnt and partially burnt fuel with air. The duration of the after burning phase may correspond to 70-80 degrees of crank travel from TDC.

## **Combustion Process of Spark Ignition Engine**

### **Phase of Combustion**

In spark ignition engines a sufficiently homogeneous mixture of vaporized liquid fuel, air and residual gases is ignited by an electric spark. The charge near the spark gap burns soon after the spark is applied. A flame develops and it spreads progressively over the entire mixture.

From the flame trace, it can be observed that flame travel can be divided into three periods. Each of these periods constitutes one phase of the combustion process.

#### **The First Phase**

This is the initial phase of low but rapidly increasing flame velocity. A small volume of mixture in the very high temperature zone between the spark plug electrodes ignites soon after the spark is applied. The burning gases gradually transform into a developed flame front. At the beginning the volume of mixture taking part in combustion is small. The flame velocity is also low since it is decreased due to heat transfer to the adjacent cylinder walls. As a result the rate of energy release during this phase is low. Therefore, the pressure rise inside the cylinder due to combustion is not appreciable.

#### **Second Phase**

This is the period of practically constant flame velocity. During this phase the flame front rapidly spreads over the major part of the mixture. The rate of combustion is high due to the influence of large scale turbulence. Heat transfer to the cylinder wall is low because only a small part of the burning mixture comes in contact with the cylinder wall during this period. The rate of heat release during this phase depends largely on the turbulence intensity and to a lesser extent on reaction rate dependent on mixture combustion. The rate of pressure rise is proportional to the rate of heat release because during this phase the combustion chamber volume remains practically constant. The beginning of this phase of combustion in spark ignition engine is taken at the point where the curve of combustion separates from the curve of compression in the pressure crank angle diagram fig1.1.

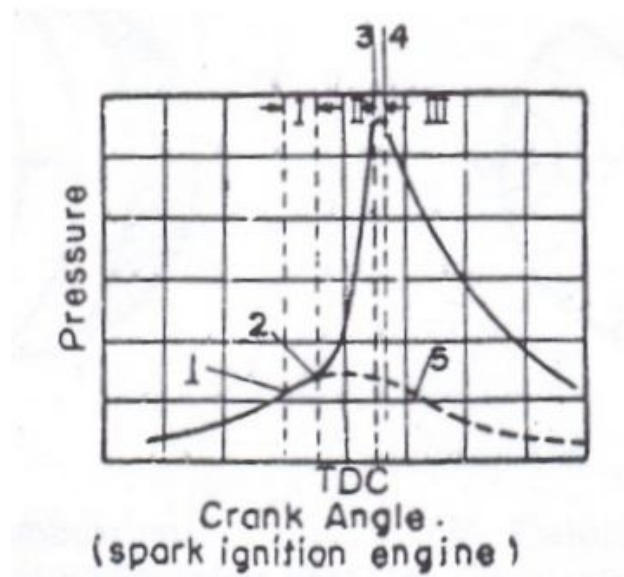

- 1 – Spark point,                      1-2 – First phase,  
 2-3 – Second Phase,    3-4 – Third phase,  
 5 – Curve with no combustion.

*Fig. Pressure versus crank angle diagram of a spark ignition engine*

### **Third Phase**

During this phase of combustion the flame velocity decreases. The flame front here approaches the wall of the combustion chamber where the turbulence intensity is low. The temperatures of the mixture layers are comparatively low due to increased heat transfer through the walls. All these factors decrease the flame velocity. The combustion rate becomes low due to low flame velocity and reduced surface of flame front. There is practically no pressure rise during this phase due to expansion of the gas. The starting point of this phase is usually taken as the instant at which the maximum pressure is reached on the indicator diagram.

## **Explain Influence of some important factors on combustion?**

### **Composition of mixture**

The composition of the mixture specified by the air coefficient  $\phi$  influences the rate of reaction and the amount of heat release. This also affects the pressure and temperature of the gases in an engine cylinder.

Experimental data obtained during the engine test using different air coefficient show that with optimum ignition advance corresponding to best power condition in each case, the power developed by the engine is the maximum where  $\phi$  ranges between 0.85 to 0.9. The velocity of flame propagation also has highest value for this mixture. When the air coefficient is increased above 0.9, the maximum pressure of the cycle drops decreasing the output of the engine. When the mixture is made much leaner the combustion in the engine becomes unstable due to reduced flame velocity.

### **Compression ratio**

The pressure and temperature of the mixture at the beginning of combustion are increased by increasing the compression ratio. The concentration of residual gases in the mixture is also reduced at high compression ratio. Both these factors increase the rate of combustion in the main phase and reduce the duration of the initial phase. However, high compression ratio increases the last phase of combustion resulting in comparatively hot exhaust.

### **Load**

When an engine operates on part load the inlet pressure is reduced by partially closing the throttle valve. This results in reduced compression pressure and larger concentration of residual gases. Both these factors reduce the flame velocity and prolong the initial phase of combustion. Combustion process also becomes unstable due to low concentration of fuel in the mixture. The difficulty can be overcome by enrich the mixture at very low loads. Rich mixture at low loads enhances the presence of unburnt products in the exhaust gas.

## **Speed**

With increase in speed the turbulence intensity in the mixture increases. The velocity of the flame front increases due to increased turbulence intensity and therefore, the duration of combustion process become shorter. With optimum ignition of advance in each speed the effect of increased speed on the last phase of combustion is compensated by reduced heat transfer. The efficiency of combustion process practically remains the same when speed is changed.

## **Shape of combustion chamber**

A centrally located spark plug in a hemispherical combustion chamber will reduce the path traveled by the flame front. The surface area of the flame front is also increased. As a result the rate of heat release is higher than other types of combustion chambers. The turbulence intensity in the mixture can be increased by properly shaped combustion chamber with a narrow passage between the piston crown and the bottom of cylinder head through which the charge flows to the combustion chamber. With suitable design of combustion chamber the heat release rate can be increased.

When an engine operates on part load the inlet pressure is reduced by partially closing the throttle valve. This results in reduced compression pressure and larger concentration of residual gases. Both these factors reduce the flame velocity and prolong the initial phase of combustion. Combustion process also becomes unstable due to low concentration of fuel in the mixture. The difficulty can be over come by enrich the mixture at very low loads. Rich mixture at low loads enhances the presence of unburnt products in the exhaust gas.

## Unit – V

1. Following data refer to a four stroke double acting diesel engine having cylinder Diameter 200 mm and Piston stroke 350 mm.

MEP on cover side	=	6.5 bar
MEP on crank side	=	7 bar
Speed	=	420 rpm
Diameter of the Piston rod	=	20mm
Dead load on the brake	=	1370 N
Spring balance reading	=	145 N
Brake wheel diameter	=	1.2 m
Brake rope diameter	=	20 mm

Calculate mechanical efficiency

### Given

Double acting 4 stroke Diesel engine

$$D = 200 \times 10^{-3} \text{ m}$$

$$L = 350 \times 10^{-3} \text{ m}$$

$$P_{m1} = 6.5 \text{ bar}$$

$$P_{m2} = 7 \text{ bar}$$

$$N = 420 \text{ rpm}$$

$$d = 20 \times 10^{-3} \text{ m}$$

$$s = 145 \text{ N}$$

$$D_w = 1.2 \text{ m}$$

$$d_r = 20 \times 10^{-3} \text{ m}$$

$$\text{To find } \eta_m = \frac{BP}{IP}$$

$$IP = \frac{100LNw[P_{m1}A_2 + P_{m2}A_2]}{60} \text{ kW}$$

$$NW = \frac{N}{2} = \frac{420}{2} = 210 \text{ rpm (4 Stroke)}$$

$$\begin{aligned}
A_1 &= \frac{\pi}{4} D^2 \\
&= \frac{\pi}{4} (200 \times 10^{-3})^2 \\
&= 0.0314 \text{ m}^2 \\
A_2 &= A_1 - \frac{\pi}{4} d^2 \\
&= 0.0314 - \frac{\pi}{4} (20 \times 10^{-3})^2 \\
&= 0.0314 - \frac{\pi}{4} (20 \times 10^{-3})(20 \times 10^{-3}) \\
&= 0.0310 \text{ m}^2 \\
\text{IP} &= \frac{100 \times 350 \times 10^{-3} \times 210 (6.5 \times 0.0314 + 7 \times 0.0310)}{60} \\
&= 51.66 \text{ kW}
\end{aligned}$$

To find BP (Rope brake dyna)

$$\begin{aligned}
\text{BP} &= \frac{(w - s)\pi(D_w + d_r)N}{60} \\
&= \frac{(1370 - 145)\pi(1.2 + 20 \times 10^{-3})420}{60} \\
&= 32.86 \text{ kW} \\
\eta_m &= \frac{32.86}{57.66} = 0.63 = 63\%
\end{aligned}$$

2. A single cylinder four stroke diesel engine having a swept volume  $730 \text{ cm}^3$  is tested at 300 rpm when a braking torque of 65 N is applied to mean effective pressure of 1100  $\text{kN/m}^2$  calculate Brake Power and mechanical efficiency.

**Solution**

$$\begin{aligned}
\text{B.P} &= \frac{2\pi NT}{60} \text{ kW} \\
\eta_{\text{mech}} &= \frac{\text{B.P}}{\text{I.P}} \\
\text{I.P} &= \frac{100 \text{ pm LAN}}{60}
\end{aligned}$$



$$B.P = \frac{2\pi NT}{60} = \frac{2\pi \times 300 \times 65}{60}$$

$$= 2.042 \text{ kw}$$

$$IP = \frac{100 p_m LAN}{60}$$

$$= \frac{100 \times 11 \times 750 \times 10^{-6} \times 150}{60}$$

$$= 2.0625 \text{ kW}$$

$$\eta_{mech} = \frac{B.P}{I.P} = \frac{2.042}{2.0625}$$

$$= 99\%$$

3. A four cylinder two stroke petrol engine develops 20 kW brake power and runs at 2500 rpm. Design an engine which is having 8 bar mean effective pressure on 85% mechanical efficiency take stroke of an engine is 1.5 times of bore.

**Given**

4 Cylinder, 2 stroke, SI engine

$$BP = 20 \text{ kW}$$

$$N = 2500 \text{ rpm}$$

$$p_m = 8 \text{ bar}$$

$$\eta_m = 85\% = 0.85$$

$$L = 1.5 D$$

**Find D, L (Design)**

$$\eta_m = \frac{B.P}{I.P}$$

$$0.85 = \frac{20}{IP}$$

$$\Rightarrow IP = \frac{20}{0.85}$$

$$\Rightarrow IP = \frac{2000}{85} = 23.52 \text{ kW}$$

$$IP = \frac{K 100 p_m LAN_w}{60}$$

K = Number of cylinder

$$N_w = N \text{ (2 stroke)}$$

$$23.52 = \frac{4 \times 100 \times 8 \times 1.50 \times \pi \times D^2 \times 2500}{4 \times 60}$$

$$23.52 \times 4 \times 60 = 4 \times 100 \times 8 \times \pi \times 250 \times 1.5 D \times D^2$$

$$D \times D^2 = \frac{23.52 \times 4 \times 60}{4 \times 100 \times 8 \times \pi \times 250 \times 1.5}$$

$$D^3 = 1.497 \times 10^{-3}$$

$$D = 1.144 \times 10^{-3} \text{ m}$$

$$\therefore L = 1.5 D = 1.716 \times 10^{-3} \text{ m}$$

4. A four cylinder diesel engine works on lower stroke has cylinder bore of 90 mm and the stroke of 150mm. The crank speed of 370 rpm fuel consumed by the engine 15 kg/hr and its calorific value 39000 kJ/kg the indicated mean effective pressure is 5 bar of compression ratio of an engine is 14 and cut off ratio is 2.3. Calculate relative efficiency of an engine if  $\gamma=1.4$

**Given**

4 cylinder, 4 stroke Diesel engine

$$K = 4, N_w = \frac{N}{2}, D = 90 \times 10^{-3} \text{ m}$$

$$L = 150 \times 10^{-3}, N = 370 \text{ rpm}$$

Indicated.m.e.  $p = 5 \text{ bar}$

$$m_f = 15 \text{ kg/hr}$$

$$CV = 39000 \text{ kJ/kg}$$

$$r = 14$$

$$\text{Cut-off} = 2.3$$

$$\gamma = 1.4$$

**Find**

$\eta$  relative

**Solution**

$$\eta_{relative} = \frac{\text{Indicated thermalefficiency}}{\text{Air standardefficiency}}$$

To find  $I_n$  th  $\eta$

$$\eta_{I.th} = \frac{IP \times 3600}{mf \times CV}$$

$$\begin{aligned} IP &= \frac{K 100 pm.LAN_w}{60} kW \\ &= \frac{4 \times 100 \times 5 \times 150 \times 10^{-3} \times \pi \times 90 \times 10^{-3} \times 185}{60 \times 4} \\ &= 5.8 \text{ kW} \end{aligned}$$

To find

$$\begin{aligned} \eta_{I.th} &= \frac{5.8 \times 3600}{15 \times 3900} \\ &= 3.52 \% \end{aligned}$$

$$\begin{aligned} \eta_{air \text{ std}} &= 1 - \frac{1}{(r)^{\gamma-1}} \left[ \frac{\delta^{\gamma} - 1}{\gamma(p-1)} \right] \\ &= 1 - \frac{1}{(14)^{0.4}} \left[ \frac{(2.3)^{1.4} - 1}{1.4(2.3 - 1)} \right] \\ &= 0.57 \% \end{aligned}$$

$$\text{Now, } \eta_{re} = \frac{3.62}{0.57} = 6.35\%$$

**5. The following particular obtain in trial in a 4 stroke gas engine**

Duration of trial	=	1 hr
Revolution	=	14000
No. of missed cycle	=	500
Net load	=	1470N
Mean eff. Pressure	=	7.5 bar
Gas consumption	=	20000 lit
L.C.V. of gas supply condition	=	21 KJ/lit
Cylinder Diameter	=	250mm
Stroke	=	450mm
Effective break circumference	=	4m
Compression ratio	=	6.5

Determine (1) IP (2) BP (3)  $\eta_m$  (4)  $\eta_{I.th}$  (5)  $\eta_{relative}$

### Given data

4 stroke gas engine (Petrol) (Otto cycle)

Duration = 1 hr

$$N_w = \frac{N}{2} = \frac{14000}{2} = 7000 \text{ rpm}$$

Missed cycle =  $500 \times 2 = 1000$  rpm

Net speed ( $N_w$ ) =  $14000 - 1000 = 13000$  rpm

$$(W-S) = 1470 \text{ N}$$

$$p_m = 7.5 \text{ bar}$$

$$mf = 20,000 \text{ lit}$$

$$LCB = 21 \text{ kJ/lit}$$

$$D = 250 \times 10^{-3} \text{ m}$$

$$L = 400 \times 10^{-3} \text{ m}$$

$$\pi D = 4 \text{ m}$$

$$r = 6.5: 1 = 6.5$$

Now,

$$B.P = \frac{(W - S)\pi DN}{60} = \frac{1470 \times \pi \times 0.25 \times 216.66}{60}$$

$$B.P = 4.16 \text{ kW}$$

$$I.P = \frac{100 pm LAN_w}{60} = \frac{100 \times 7.5 \times 0.4 \times \frac{\pi}{4} \times 0.25^2 \times 6500}{60}$$

$$= 1595.34 \text{ KW}$$

To find BP

$$BP = \frac{(W - S)\pi D.N}{60}$$

$$= \frac{1470 \times 4 \times 13000}{60}$$

$$= 1274 \text{ kw}$$

$$\text{To find } \eta_{\text{mech}} = \frac{B.P}{I.P}$$

$$= \frac{1274}{1595.34}$$

$$= 79.85 \%$$

To find  $\eta_{I,thermal}$

$$\eta_{I,thermal} = \frac{I.P \times 3600}{mf \times C.V}$$

$$= \frac{1595.34 \times 3600}{2000 \times 21}$$

$$= 13.67 \%$$

To find  $\eta_{relative} = \frac{\eta_{I,th}}{\eta_{assisted}}$

$$\eta_{air} = 1 - \frac{1}{(r)^{\gamma} - 1}$$

**6. A test was conducted in a 4-stroke single cylinder SI engine having 7 cm diameter and 9 cm stroke. The fuel supply to the engine is 0.065 kg/m. The B.P measurements are given below with constant speed of an engine.**

1. With all cylinder firing = 16.9 kW
2. Cut off at 1<sup>st</sup> cylinder = 8.46 kW
3. Cut off at 2<sup>nd</sup> cylinder = 8.56 kW
4. Cut off at 3<sup>rd</sup> cylinder = 8.6 kW
5. Cut off at 1<sup>st</sup> cylinder = 8.46 kW

If clearance volume 69.5 cm<sup>3</sup> find Indicate Power, Indicated thermal efficiency also compare the thermal efficiencies.

Take CV = 43500 kJ/kg

**Solution**

Given

4S, SI engine

- D = 7 cm
- L = 9 cm
- mf = 0.065 kg/min
- CV = 43500 KJ/kg
- BP = 16.9 kW

$$\begin{aligned}
V_c &= 69.5 \\
BP_1 &= 8.46 \text{ kW} \\
BP_2 &= 8.56 \text{ kW} \\
BP_3 &= 8.6 \text{ kW} \\
BP_4 &= 8.5 \text{ kW}
\end{aligned}$$

**Find**

$$\begin{aligned}
&\text{(i) IP} && \text{(ii) In th}\eta && \text{(iii) } \eta_{\text{rel}} = \frac{\text{In.th}\eta}{\text{Air Std}\eta}
\end{aligned}$$

**Solution**

$$\begin{aligned}
IP_1 &= BP - BP_1 \\
IP_1 &= 16.9 - 8.46 \\
IP_1 &= 8.44 \text{ Kw} \\
IP_2 &= BP - BP_2 \\
&= 16.9 - 8.56 \\
IP_2 &= 8.34 \text{ kW} \\
IP_3 &= BP - BP_3 \\
&= 16.9 - 8.6 \\
IP_3 &= 8.3 \text{ kW} \\
IP &= IP_1 + IP_2 + IP_3 + IP_4 \\
&= 8.44 + 8.34 + 8.3 + 8.4 \\
IP &= 33.48 \text{ kW} \\
\text{In th}\eta &= \frac{IP \times 60}{mf \times CV} = \frac{33.48 \times 60}{0.065 \times 43500} \\
\eta_{\text{In th}} &= 71.04\% \\
\eta_{\text{air}} &= 1 - \frac{1}{(r)^{\gamma-1}}
\end{aligned}$$

$$\begin{aligned}
r(\text{compression ratio}) &= \frac{\text{Total Volume}}{\text{Volume}} \\
&= \frac{V_c + V_s}{V_c}
\end{aligned}$$

$$V_s = \frac{\pi}{4} D^2 L$$

$$\begin{aligned}
&= \frac{\pi}{4} \times 7^2 \times 9 \\
&= \frac{\pi}{4} \times 49 \times 9 \\
&= 346.36 \text{ cm}^3 \\
r &= \frac{69.6 + 346.36}{69.6} = 5.98 \\
\eta_{air} &= 1 - \frac{1}{(5.98)^{0.4}} \\
\eta_{air} &= 51.09\% \\
\eta_{rel} &= \frac{\eta_{In.th}}{\eta_{air}} = 1.39\%
\end{aligned}$$

7. The following observation were recorded in a test of hour duration a single cylinder oil engine on four stroke cycle.

Bore	=	300 mm
Stroke	=	450 mm
Fuel used	=	5.5 kg
Calorific value	=	41800 kJ/kg
Avg. speed	=	200 rpm
Brake load	=	1860 N
MEP	=	5.8 bar
Quantity of cooling water	=	650 kg
Temperature rise in water	=	22°C
Diameter of brake wheel	=	1.22 m

Calculate Mech efficiency, B th  $\eta$  also draw heat balance sheet

### Solution

**Given data,** SS, 4S, SI engine

$$\begin{aligned}
D &= 0.3\text{m} & \Delta T_w &= 22^\circ\text{C} \\
L &= 0.45\text{m} & D_w &= 1.22\text{m} \\
m_f &= 8.8 \text{ kg/hr} & R &= \frac{1.22}{2} = 0.61 \text{ m}
\end{aligned}$$

$$\begin{aligned}
CV &= 41800 \text{ kJ/kg} \\
N &= 2.00 \text{ rpm} \\
W &= 1860 \text{ N} \\
p_m &= 5.8 \text{ bar} \\
m_w &= 650 \text{ kg/hr} \\
BP &= \frac{2\pi NT}{60} \text{ kW}
\end{aligned}$$

(Bony Brea)

$$\begin{aligned}
\text{Brake Torqu (T)} &= w.R \\
&= 1860 \times 0.61 \text{ N-m} \\
&= 1134.6 \text{ J,} \\
BP &= \frac{2\pi NT}{60} \\
&= \frac{2\pi \times 200 \times 1134.6}{60} \\
&= 23763.006 \text{ W} \\
BP &= 23.75 \text{ kW} \\
IP &= \frac{100 \text{ pm KANw}}{60} \\
&= \frac{100 \times 5.8 \times 450 \times 10^3}{60} \\
IP &= 30.74 \text{ kW} \\
\eta_m &= \frac{BP}{IP} \\
&= \frac{23.75}{30.74} \times 100 \\
&= 77.3 \%
\end{aligned}$$

To find  $\eta_{Bth}$

$$\begin{aligned}
\eta_{Bth} &= \frac{BP \times 3600}{mf \times CV} = \frac{23.75 \times 3600}{8.8 \times 41800} \\
&= 23.25 \%
\end{aligned}$$

For the Heat Balance Sheet



Total Heat supply by the fuel

$$\begin{aligned}\text{Heat supply} &= m_f \times CV \\ m_f &= 8.8 \text{ Rg/hr} \\ CV &= 41800 \text{ kJ/kg} \\ Q_s &= 8.8 \times 41800 \\ &= \frac{8678400}{60} \text{ kJ/hr} = 6130 \text{ kJ/min}\end{aligned}$$

Heat absorb to produce indicated power

$$\begin{aligned}\text{I.P} &= \frac{100 P_m \text{ LAN}}{60} \text{ kW} \\ \text{I.P} &= 30.74 \text{ kW} \\ &= 30.74 \times 60 = 1844.4 \text{ kJ/min}\end{aligned}$$

Heat rejected cooling water

$$\begin{aligned}Q_{CW} &= m_{cw} C_{pw} (T_{wo} - T_{ci}) \\ Q_{CW} &= m_{cw} C_{pw} (\Delta T)_{cw} \\ &= 650/60 \times 4.2 \text{ (2)} \\ &= 997.66 \text{ KJ/min}\end{aligned}$$

Heat carried away by the exhaust Gases

$$Q_g = m_g C_{pg} (\theta T)_g = 0$$

because it is not given

**Uncountable Heat**

$$\begin{aligned}Q_s - (\text{IP} + Q_{RW} + Q) \\ = 3673400 - (110664 + 60060) = 3507676 \text{ kJ/hr.}\end{aligned}$$

$$\% Q \text{ to I.P} = \frac{Q \text{ to I.P}}{Q_s} \times 100$$

$$= \frac{18444}{3678400} \times 100$$

$$\% Q \text{ to } C_w = \frac{997.66 \times 100}{6130.68}$$

$$= 16.27\%$$

$$\% Q \text{ to exhaust Gas} = 0$$

$$\begin{aligned} \% Q \text{ to uncountable} &= \frac{3288.58}{6130.68} \times 100 \\ &= 53.64\% \end{aligned}$$

### Heat Balance Sheet

SL.No.	Particulars	Heat	
		KJ/hr	%
	<b>Total Heat supply by the fuel</b>	<b>6130.68</b>	<b>100%</b>
1.	Heat to indicated power	1844.4	10.5
2.	Heat Rejected to water	997.66	16.27
3.	Heat taken by exhaust gas	0	0
4.	Unaccountable	3288.58	53.64%
	<b>Total</b>	<b>6130.68</b>	<b>100%</b>

### 8. The following data is given on a single cylinder 4-S oil engine

Cylinder diameter	=	18 cm
Stroke	=	36 cm
Engine speed	=	286 rpm
Brake torque	=	375 N-m
Indicated mean effective pressure	=	7 bar
Fuel consumption	=	3.88 Lit/hr
Sp. gravity of fuel	=	0.8
Calorific value of fuel	=	44500 KJ/kg
Then air fuel ratio used	=	25:1
ambient air temperature	=	21°C
Specific heat of gas	=	12 kJ/kg k
Exhaust gas temperature	=	415°C
Cooling water circulated	=	4.2 Kg/min
Rise in temperature in cooling water	=	28.5 °C

find (1)  $\eta_{\text{mech}}$  (2)  $I_{\text{th},\eta}$  (3) draw heat balance sheet on % basis.

**(i) Given**

SS, 4S oil engine

$$D = 18 \times 10^{-2} \text{ m}$$

$$T_a = 21^\circ\text{C}$$

$$L = 36 \times 10^{-2} \text{ m}$$

$$(C_p)_{\text{gas}} = 1.2 \text{ KJ/kgk}$$

$$N = 286 \text{ rpm}$$

$$T_{\text{ex gas}} = 415^\circ\text{C}$$

$$T = 375 \text{ N}$$

$$m_c = 4.2 \text{ kg/min}$$

$$p_m = 7 \text{ bar}$$

$$(\Delta T)_c = 28.5^\circ\text{C}$$

$$m_f = 3.88 \text{ lit/hr}$$

$$\text{specific} = 0.8$$

gravity

$$\text{CV} = 44500 \text{ KJ/hr}$$

$$\text{Air-fuel ratio} = \frac{m_a}{m_f} = 25$$

$$m_a = 25 \times m_f$$

**Solution**

$$m_f = 3.88 \text{ lit/hr}$$

$$= 3.88 \times 10^{-3} \text{ m}^3/\text{hr}$$

**WKT**

$$\delta = \frac{m}{V}$$

$$m = \delta v$$

$$= 800 \times 3.88 \times 10^{-3}$$

$$= 3.10 \text{ kJ/hr}$$

$$\text{sp.gr} = \frac{\text{Density of fuel}}{\text{density of std substance}}$$

$$= \frac{\delta_f}{\delta_{\text{water}}}$$

$$\delta_f = \text{Sp. gv} \times \delta_w$$

$$= 0.8 \times 100$$

$$= 800 \text{ kg/m}^3$$

∴ to find  $\eta_m$

$$\eta_m = \frac{BP}{IP}$$

$$BP = \frac{2\pi NT}{60} KW$$

$$= \frac{2\pi \times 286 \times 375}{60}$$

$$BP = 11.23 \text{ KW}$$

$$IP = \frac{100 pm LAN_w}{60}$$

$$= 15.28 \text{ kW}$$

$$N_w = \frac{N}{2} = \frac{286}{2} = 143 \text{ (4 stroke)}$$

$$\eta_m = \frac{11.23}{15.28} = 73.19\%$$

$$\eta_{m.th} = \frac{I_p \times 60}{\frac{mf}{60} \times CV} = \frac{I_p \times 3600}{m_f \times C_v} = \frac{15.28 \times 3600}{3.17 \times 44500}$$

### To prepare heat balance sheet

Heat supplied by the fuel

$$Q_s = m_f \times CV$$

$$= \frac{3.104}{60} \times 44500$$

$$Q_s = 2302.13 \text{ kJ/min}$$

$$\% \text{ of } Q_s = 100\%$$

Heat carried away by  $C_w$

$$Q_c = m_c Q_c (\Delta T) c$$

$$= 4.2 \times 4.186 (28.5)$$

$$Q_c = 501.06 \text{ kJ/min}$$

$$\% \text{ of } Q_c = \frac{501.06}{2302.13} \times 100$$

$$\% Q_c = 21.76\%$$

Heat taken by or gas

$$Q_g = m_g \cdot C_{p,g} (\Delta T) g$$

$$\begin{aligned}
 &= m_g C_{pg} (T_g - T_a) & \text{mass of air} &= 25 \times \frac{3.104}{60} \\
 &= 1.29 \times 1.2 (415 - 21) & &= 1.29 \text{ Kg/min} \\
 &= 609.91 \text{ kJ/min} \\
 \% Q_g &= \frac{609.91}{2302.13} \times 100 \\
 Q_g &= 26.46\%
 \end{aligned}$$

Unaccounted heat

$$\begin{aligned}
 Q_{IP} &= 15.28 \times 60 \\
 &= 916.8 \text{ KJ/min} \\
 \% Q_{IP} &= 39.8\%
 \end{aligned}$$

$$\begin{aligned}
 \text{Unaccounted heat} &= Q_s - [Q_{IP} + Q_c + Q_g] \\
 &= 2302.13 - [916.8 + 501.06 + 609.91] \\
 &= 274.36 \text{ KJ/min}
 \end{aligned}$$

$$\begin{aligned}
 \% \text{ of } Q_{un} &= \frac{274.35}{2302.13} \times 100 \\
 &= 11.9\%
 \end{aligned}$$

### Heat Balance Sheet

SL.No.	Particulars	Heat	
		KJ/hr	%
	<b>Total Heat supply by the fuel</b>	<b>2302.13</b>	<b>100</b>
1.	Heat to indicated power	916.8	38.82
2.	Heat Rejected to water	501.06	21.26
3.	Heat taken by exhaust gas	609.91	29.49
4.	Unaccountable	284.36	11.9
	<b>Total</b>	<b>4604.26</b>	<b>100%</b>

9. Following data refers to a four stroke double acting diesel engine having cylinder diameter 200 mm and piston stroke 350 mm.

m.e.p. on cover side	=	6.5 bar
m.e.p. on crank side	=	7 bar
Speed	=	420 r.p.m
Diameter of piston rod	=	20 mm
Dead load on the brake	=	1370 N
Spring balance reading	=	145 N
Brake wheel diameter	=	1.2 m
Brake rope diameter	=	20 m

Calculate the mechanical efficiency of the engine.

**Solution:**

$$P_{mi(\text{cover})}=6.5 \text{ bar}, p_{mi(\text{crank})} = 7 \text{ bar}, D=0.2\text{m}, L=0.35\text{m},$$

$$N = 420 \text{ r.p.m}, d_{rod} = 20 \text{ mm} = 0.02\text{m}, W=1370\text{N}, S=145 \text{ N}$$

$$D_b=1.2\text{m}, d=0.02\text{m}, N\omega = \frac{N}{2} \dots 4\text{-stroke cycle engine.}$$

**Mechanical Efficiency :  $\eta_{\text{mech}}$**

Area of cylinder on cover and side,

$$A_{\text{cover}} = \pi/4 D^2 = (\pi/4) \times (0.2)^2 = 0.03141 \text{ m}^2$$

Effective area of cylinder on crank end side,

$$I.P. (\text{Cover}) = \pi/4 (D^2 - d_{rod}^2) = \pi/4 (0.2^2 - 0.02^2) = 0.0311 \text{ m}^2$$

Indicated power on crank end side,

$$I.P. (\text{cover}) = \frac{p_{mi(\text{cover})} \times L A N k \times 10}{6}$$

$$= \frac{6.5 \times 0.35 \times 0.03141 \times 420 \times \frac{1}{2} \times 10}{6} = 25 \text{ kW}$$

Indicated power on crank end side,

$$I.P. (\text{crank}) = \frac{p_{mi(\text{crank})} \times L A N k \times 10}{6}$$

$$= \frac{7 \times 0.35 \times 0.03141 \times 420 \times \frac{1}{2} \times 10}{6} = 26.67 \text{ kW}$$

Total I.P = 25 + 26.67 = 51.67 kW

Now, brake power, B.P =  $\frac{(W - S)\pi(D_b + d)N}{60 \times 1000} = \frac{(1370 - 145)\pi(1.2 + 0.02) \times 420}{60 \times 1000} \text{ kW}$   
= 32.86 kW

Mechanical efficiency,  $\eta_{\text{mech}} = \frac{B.P}{I.P} = \frac{32.86}{51.67} = 0.6359 = 63.59\%$  (Ans.)

**10. The following particulars were obtained in a trial on a 4-stroke gas engine:**

- Duration of trial = 1 hour
- Revolutions = 14000
- Number of missed cycle = 500
- Net brake load = 1470N
- Mean effective pressure = 7.5 bar
- Gas consumption = 20000 litres
- L.C.V of gas at supply condition = 21 kJ/litre
- Cylinder diameter = 250 mm
- Stroke = 400 mm
- Effective brake circumference = 4 m
- Compression ratio = 6.5:1

- Calculate: (i) Indicated power (ii) Brake power  
(iii) Mechanical efficiency (iv) Indicated thermal efficiency  
(v) Relative efficiency

**Solution**

$$N = \frac{14000}{60} = \frac{700}{8} \text{ r.p.m. } W-S = 1470 \text{ N}$$

$$P_{\text{mi}} = 7.5 \text{ bar; } V_R = \frac{2000}{3600} = 5.55 \text{ litres/s,}$$

$$D = 250 \text{ mm} = 0.25 \text{ m, } L = 400 \text{ mm} = 0.4 \text{ m}$$

$$\pi D_b = 4 \text{ m, } r = 6.5$$

**(i) Indicated Power I.P:**

$$\begin{aligned} \text{I.P. (cover)} &= \frac{P_{mi(\text{cover})} \times LAN_w \times 10}{6} \\ N_w &= \left( \frac{14000}{2} - 500 \right) / 3600 = \frac{6500}{60} \text{ working cycles/min} \\ &= \frac{1 \times 7.5 \times 0.4 \times \pi / 4 \times 0.25^2 \times (6500/60) \times 10}{6} \\ &= \mathbf{26.59 \text{ kW (Ans)}} \end{aligned}$$

**(ii) Brake Power,**

$$\text{Now, brake power, B.P} = \frac{(W - S)\pi(D_b + d)N}{60 \times 1000} = \frac{1470 \times 4 \times (700/3)}{60 \times 1000} = 22.86 \text{ kW}$$

**(iii) Mechanical Efficiency,  $\eta_{\text{mech}}$**

$$\eta_{\text{mech}} = \frac{B.P}{I.P} = \frac{22.86}{26.59} = 0.859 \text{ or } 85.9\% \text{ (Ans.)}$$

**(iv) Indicated thermal efficiency,  $\eta_{\text{th(1)}}$**

$$\eta_{\text{th(1)}} = \frac{I.P}{V_g \times C} = \frac{26.59}{5.5 \times 21} = 0.23 \text{ or } 23\% \text{ (Ans)}$$

**(v) Relative efficiency,  $\eta_{\text{relative}}$**

$$\begin{aligned} \eta_{\text{relative}} &= \frac{\eta_{\text{thermal}}}{n_{\text{air-standard}}} \\ \eta_{\text{air-standard}} &= 1 - \frac{1}{(r)^{\gamma-1}} = 1 - \frac{1}{(6.5)^{1.4-1}} = 0.527 \text{ or } 52.7\% \\ \eta_{\text{relative}} &= \frac{0.23}{0.527} = 0.436 \text{ or } 43.6\% \text{ (Ans)} \end{aligned}$$

**11. In a trial of a single cylinder oil engine working on dual cycle, the following observations were made**

Compression ratio	=	15
Oil consumption	=	10.2 kg/h
Calorific value of fuel	=	43890 kJ/kg
Air consumption	=	3.8 kg/min
Speed	=	1900 r.p.m
Torque on the brake drum	=	186 N-m



Quantity of cooling water used = 15.5 kg/min  
 Temperature rise = 36°C  
 Exhaust gas temperature = 410°C  
 Room temperature = 20°C  
 $c_p$  for exhaust gases = 1.17 kJ/kgK

**Calculate :** (i) Brake power,  
 (ii) Brake specific fuel consumption and  
 (iii) Brake thermal efficiency

Draw heat balance sheet on minute basis.

**Solution:**  $n=1$ ,  $r=15$ ,  $m_f=10.2$  kg/h,  $C=43890$  kJ/kg,  $m_a=3.8$  kg/min,  $N=1900$  r.p.m.,  
 $T=186$  N-m,  $m_w=15.5$  kg/min,  $t_{w2}-t_{w1}=36^\circ\text{C}$ ,  $t_g=410^\circ\text{C}$ ,  $t_r=20^\circ\text{C}$ ,

**(i) Brake Power, B.P:**

$$B.P = \frac{2\pi NT}{60 \times 1000} = \frac{2\pi \times 1900 \times 186}{60 \times 1000} = 37 \text{ kW}$$

**(ii) Brake specific fuel consumption b.s.f.c:**

$$\text{b.s.f.c.} = \frac{10.2}{37} = 0.2756 \text{ kg / kWh.}$$

**(iii) Brake thermal efficiency,**

$$\eta_{\text{th(B)}} = \frac{B.P}{m_f \times C} = \frac{37}{\frac{10.2}{3600} \times 43890} = 0.2975 \text{ or } 29.75\% \text{ (Ans.)}$$

$$= \frac{10.2}{60} \times 43890 = 7461 \text{ kJ / min}$$

**(i) Heat equivalent B.P**

$$= B.P \times 60 = 37 \times 60 = 2220 \text{ kJ/min}$$

**(ii) Heat carried away by cooling water**

$$= m_w \times c_{pg} \times (t_g - t_r)$$

$$= \left( \frac{10.2}{60} + 3.8 \right) \times 1.17 \times (410 - 20) = 1811 \text{ kJ / min}$$

<b>Item</b>	<b>KJ/hr</b>	<b>%</b>
Heat supplied by fuel	7461	100
i. Heat absorbed in B.P	2220	29.8
ii. Heat taken away by cooling water	2332	31.2
iii. Heat carried away exhaust gases	1811	24.3
iv. Heat unaccounted for (by difference)	1098	14.7
Total	7461	100